

6P Series Pipe Fittings

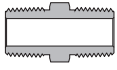

Contents

Hex Nipples - PHN



A-117

Hex Long Nipples - PLN

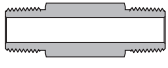

A-121

Close Nipples - PCN

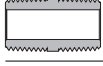

A-122

Special Pipe Nipples - PSN

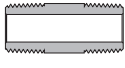

A-122

Adapters - PA



A-123

Reducing Bushings - PRB



A-126

Hex Couplings - PCG



A-129

Union Ball Joints - UBJ



A-130

Male Elbows - PME



A-130

Street Elbows - PSE



A-131

45° Street Elbows - PSV

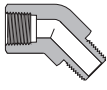

A-133

Female Elbows - PE



A-135

45° Female Elbows - PVE

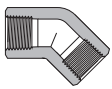

A-136

Male Tees - PMT

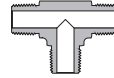

A-137

Female Branch Tees - PTB

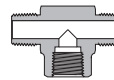

A-138

Female Run Tees - PTR

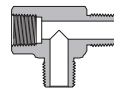

A-138

Male Street Tees - PST

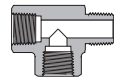

A-139

Male Branch Tees - PBT

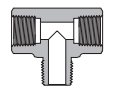

A-140

Female Tees - PT

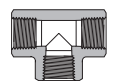

A-141

Female Crosses - PCR

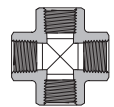

A-142

Pipe to Pipe Unions - PUP

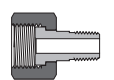

A-142

Hand Tight Adapter Fittings - HF

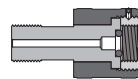

A-143

Pipe Plugs - PP



A-144

Hollow Hex Plugs - PI



A-145

Pipe Caps - PC



A-146

Ordering Number Description A-147

Features

- ⦿ The hardened threads with smooth surface finishing avoid galling and help to extend the fitting service life
- ⦿ Radius junction design for elbows provides smooth flow path
- ⦿ Every fitting is marked with size, material and heat number

Technical Data

- ⦿ Sizes range from 1/16 to 2
- ⦿ Thread Specifications:

Thread Type	Specification
NPT	ASME B1.20.1, SAE A571051
ISO Tapered	ISO 7-1, BS 21, JIS B0203
ISO Parallel	ISO 228, JIS B0202
SAE/MS	ASME B1.1, SAE J475
Metric	ISO 261

- ⦿ Working Temperature:

For the working temperatures of FITOK pipe fittings, please see A-10.

- ⦿ Working Pressure:

1. Catalog working pressures shown are based on ANSI/ASME B31.3 at ambient temperature, to determine working pressures in accordance with ANSI/ASME B31.1 multiply catalog working pressures shown by the factor from the table below.

Material	Factor
Carbon steel	0.85
Brass	1.0

2. Use the allowable working pressure at ambient temperature to multiply the elevated temperature factors to get the working pressure at elevated temperature. To know the elevated temperature factor, please see F-14.
3. For technical information of NPT thread and ISO tapered thread, please see page A-06 and A-07.

Materials

Material	Bar Stock	Forging	Designator
316 stainless steel	ASTM A276, ASME SA479, EN 1.4401	ASTM A182, ASME SA182, EN 1.4401	SS
304 stainless steel	ASTM A276, ASME SA479, EN 1.4301	ASTM A182, ASME SA182, EN 1.4301	S4
Alloy 400	ASTM B164, ASME SB164	ASTM B564 ASME SB564	M
Alloy 600	ASTM B166, ASME SB166	ASTM B564, ASME SB564	INC
Alloy C-276	ASTM B574	ASTM B564,	HC
Brass	ASME B16/ASTM B453	ASTM B283	B
Carbon steel	ASTM A108	ASTM A105	CS
904L stainless steel	ASTM B649	ASTM A182	904L

Cautions:

- ⦿ Do not loosen or tighten fittings when system is pressurized.
- ⦿ Always use proper thread sealants on tapered pipe threads.
- ⦿ Confirm the sealing type when choosing the straight threads, make sure the construction of the matching threads comply with the sealing type.

Dimensions

Hex Nipples

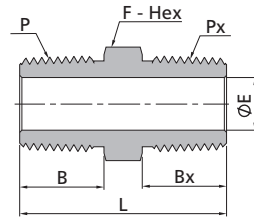

Male NPT Threads									
P-NPT Size	Px-NPT Size	Basic Ordering Number	Dimensions, in. (mm)					Working Pressure psig (bar)	
			L	F	B	Bx	E	316 SS, Steel	Brass
1/16	1/16	-PHN-NS1	1.01 (25.6)	0.31 (7.9)	0.38 (9.7)	0.38 (9.7)	0.12 (3.0)	11000 (757)	5500 (378)
1/8	1/16	-PHN-NS2-NS1	1.01 (25.6)	0.44 (11.1)	0.38 (9.7)	0.38 (9.7)	0.12 (3.0)	11000 (757)	5500 (378)
1/8	1/8	-PHN-NS2	1.01 (25.6)	0.44 (11.1)	0.38 (9.7)	0.38 (9.7)	0.19 (4.8)	10000 (690)	5000 (344)
1/4	1/16	-PHN-NS4-NS1	1.22 (31.0)	0.56 (14.3)	0.56 (14.2)	0.38 (9.7)	0.12 (3.0)	9500 (655)	4700 (324)
1/4	1/8	-PHN-NS4-NS2	1.22 (31.0)	0.56 (14.3)	0.56 (14.2)	0.38 (9.7)	0.19 (4.8)	9500 (655)	4700 (324)
1/4	1/4	-PHN-NS4	1.40 (35.6)	0.56 (14.3)	0.56 (14.2)	0.56 (14.2)	0.28 (7.1)	8000 (551)	4000 (275)
3/8	1/16	-PHN-NS6-NS1	1.25 (31.8)	0.69 (17.5)	0.56 (14.2)	0.38 (9.7)	0.12 (3.0)	7800 (537)	3900 (268)
3/8	1/8	-PHN-NS6-NS2	1.25 (31.8)	0.69 (17.5)	0.56 (14.2)	0.38 (9.7)	0.19 (4.8)	7800 (537)	3900 (268)
3/8	1/4	-PHN-NS6-NS4	1.43 (36.3)	0.69 (17.5)	0.56 (14.2)	0.56 (14.2)	0.28 (7.1)	8000 (551)	4000 (275)
3/8	3/8	-PHN-NS6	1.43 (36.3)	0.69 (17.5)	0.56 (14.2)	0.56 (14.2)	0.38 (9.7)	7800 (537)	3900 (268)
1/2	1/8	-PHN-NS8-NS2	1.47 (37.3)	0.87 (22.2)	0.75 (19.1)	0.38 (9.7)	0.19 (4.8)	7700 (530)	3800 (261)
1/2	1/4	-PHN-NS8-NS4	1.65 (41.9)	0.87 (22.2)	0.75 (19.1)	0.56 (14.2)	0.28 (7.1)	8000 (551)	4000 (275)
1/2	3/8	-PHN-NS8-NS6	1.65 (41.9)	0.87 (22.2)	0.75 (19.1)	0.56 (14.2)	0.38 (9.7)	7800 (537)	3900 (268)
1/2	1/2	-PHN-NS8	1.84 (46.7)	0.87 (22.2)	0.75 (19.1)	0.75 (19.1)	0.47 (11.9)	7700 (530)	3800 (261)
3/4	1/8	-PHN-NS12-NS2	1.59 (40.4)	1.06 (27.0)	0.75 (19.1)	0.38 (9.7)	0.19 (4.8)	7300 (502)	3600 (248)
3/4	1/4	-PHN-NS12-NS4	1.65 (41.9)	1.06 (27.0)	0.75 (19.1)	0.56 (14.2)	0.28 (7.1)	8000 (551)	4000 (275)
3/4	3/8	-PHN-NS12-NS6	1.78 (45.2)	1.06 (27.0)	0.75 (19.1)	0.56 (14.2)	0.38 (9.7)	7800 (537)	3900 (268)
3/4	1/2	-PHN-NS12-NS8	1.84 (46.7)	1.06 (27.0)	0.75 (19.1)	0.75 (19.1)	0.47 (11.9)	7700 (530)	3800 (261)
3/4	3/4	-PHN-NS12	1.84 (46.7)	1.06 (27.0)	0.75 (19.1)	0.75 (19.1)	0.62 (15.7)	7300 (502)	3600 (248)
1	1/8	-PHN-NS16-NS2	1.78 (45.2)	1.37 (34.9)	0.94 (23.9)	0.38 (9.7)	0.19 (4.8)	6500 (448)	3300 (227)
1	1/4	-PHN-NS16-NS4	1.94 (49.3)	1.37 (34.9)	0.94 (23.9)	0.56 (14.2)	0.28 (7.1)	5300 (365)	2600 (179)
1	3/8	-PHN-NS16-NS6	1.97 (50.0)	1.37 (34.9)	0.94 (23.9)	0.56 (14.2)	0.38 (9.7)	6500 (448)	3300 (227)
1	1/2	-PHN-NS16-NS8	2.13 (54.1)	1.37 (34.9)	0.94 (23.9)	0.75 (19.1)	0.47 (11.9)	6500 (448)	3300 (227)
1	3/4	-PHN-NS16-NS12	2.13 (54.1)	1.37 (34.9)	0.94 (23.9)	0.75 (19.1)	0.62 (15.7)	6500 (448)	3300 (227)
1	1	-PHN-NS16	2.32 (58.9)	1.37 (34.9)	0.94 (23.9)	0.94 (23.9)	0.88 (22.4)	5300 (365)	2600 (179)
1 1/4	1	-PHN-NS20-NS16	2.45 (62.2)	1.75 (44.5)	0.94 (23.9)	0.94 (23.9)	0.88 (22.4)	5300 (365)	2600 (179)
1 1/4	1 1/4	-PHN-NS20	2.48 (62.9)	1.75 (44.5)	0.94 (23.9)	0.94 (23.9)	1.13 (28.6)	6000 (410)	3000 (200)
1 1/2	1 1/2	-PHN-NS24	2.61 (66.3)	2.00 (50.8)	1.03 (26.2)	1.03 (26.2)	1.34 (34.0)	5000 (344)	2500 (172)
2	2	-PHN-NS32	3.06 (77.7)	2.50 (63.5)	1.06 (26.9)	1.06 (26.9)	1.77 (45.0)	3900 (268)	1900 (130)

Male ISO Tapered Threads									
P-RT Size	Px-RT Size	Basic Ordering Number	Dimensions, in. (mm)					Working Pressure psig (bar)	
			L	F	B	Bx	E	316 SS, Steel	Brass
1/8	1/8	-PHN-RT2	1.01 (25.6)	0.44 (11.1)	0.38 (9.7)	0.38 (9.7)	0.19 (4.8)	10000 (690)	5000 (344)
1/4	1/4	-PHN-RT4	1.40 (35.6)	0.56 (14.3)	0.56 (14.2)	0.56 (14.2)	0.28 (7.1)	8000 (551)	4000 (275)
3/8	3/8	-PHN-RT6	1.43 (36.3)	0.69 (17.5)	0.56 (14.2)	0.56 (14.2)	0.38 (9.7)	7800 (537)	3900 (268)
1/2	1/2	-PHN-RT8	1.84 (46.7)	0.87 (22.2)	0.75 (19.1)	0.75 (19.1)	0.47 (11.9)	7700 (530)	3800 (261)
3/4	3/4	-PHN-RT12	1.84 (46.7)	1.06 (27.0)	0.75 (19.1)	0.75 (19.1)	0.62 (15.7)	7300 (502)	3600 (248)
1	1	-PHN-RT16	2.32 (58.9)	1.37 (34.9)	0.94 (23.9)	0.94 (23.9)	0.88 (22.4)	5300 (365)	2600 (179)

Hex Nipples

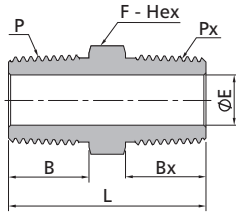

Male NPT Threads			Male ISO Tapered Threads							
P-NPT Size	Px-RT Size	Basic Ordering Number	Dimensions, in. (mm)					Working Pressure psig (bar)		
			L	F	B	Bx	E	316 SS, Steel	Brass	
1/8	1/8	-PHN-NS2-RT2	1.01 (25.6)	0.44 (11.1)	0.38 (9.7)	0.38 (9.7)	0.19 (4.8)	10000 (690)	5000 (344)	
1/4	1/4	-PHN-NS4-RT4	1.40 (35.6)	0.56 (14.3)	0.56 (14.2)	0.56 (14.2)	0.28 (7.1)	8000 (551)	4000 (275)	
3/8	3/8	-PHN-NS6-RT6	1.43 (36.3)	0.69 (17.5)	0.56 (14.2)	0.56 (14.2)	0.38 (9.7)	7800 (537)	3900 (268)	
1/2	1/2	-PHN-NS8-RT8	1.84 (46.7)	0.87 (22.2)	0.75 (19.1)	0.75 (19.1)	0.47 (11.9)	7700 (530)	3800 (261)	
3/4	3/4	-PHN-NS12-RT12	1.84 (46.7)	1.06 (27.0)	0.75 (19.1)	0.75 (19.1)	0.62 (15.7)	7300 (502)	3600 (248)	
1	1	-PHN-NS16-RT16	2.32 (58.9)	1.37 (34.9)	0.94 (23.9)	0.94 (23.9)	0.88 (22.4)	5300 (365)	2600 (179)	

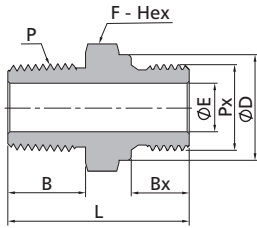

Male NPT Threads			Male ISO parallel Threads								
P-NPT Size	Px-RS Size	Basic Ordering Number	Dimensions, in. (mm)						Working Pressure psig (bar)		
			L	F	B	Bx	E	D	316 SS, Steel	Brass	
1/8	1/8	-PHN-NS2-RS2	1.09 (27.7)	0.56 (14.3)	0.38 (9.7)	0.28 (7.1)	0.16 (4.1)	0.54 (13.7)	9600 (662)	4800 (331)	
1/4	1/4	-PHN-NS4-RS4	1.45 (36.8)	0.75 (19.1)	0.56 (14.2)	0.44 (11.2)	0.23 (5.8)	0.71 (18.0)	10300 (709)	5100 (351)	
3/8	3/8	-PHN-NS6-RS6	1.48 (37.6)	0.87 (22.2)	0.56 (14.2)	0.44 (11.2)	0.31 (7.9)	0.85 (21.6)	7800 (537)	3900 (268)	
1/2	1/2	-PHN-NS8-RS8	1.75 (44.4)	1.06 (27.0)	0.75 (19.1)	0.56 (14.2)	0.47 (11.9)	1.02 (25.9)	7600 (523)	3800 (261)	
3/4	3/4	-PHN-NS12-RS12	1.93 (49.0)	1.31 (33.3)	0.75 (19.1)	0.62 (15.7)	0.62 (15.7)	1.26 (32.0)	7300 (502)	3600 (248)	
1	1	-PHN-NS16-RS16	2.23 (56.6)	1.63 (41.3)	0.94 (23.9)	0.72 (18.3)	0.78 (19.8)	1.53 (38.9)	7400 (509)	3700 (254)	

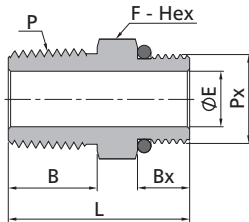

Male NPT Threads				Male SAE/MS Straight Threads (ST)					
P-NPT Size	Px-SAE Nominal Size	Px-SAE/MS Thread Specification	Basic Ordering Number	Dimensions, in. (mm)					Working Pressure psig (bar)
				L	F	B	Bx	E	316 SS, Steel
1/4	4	7/16-20	-PHN-NS4-ST7	1.20 (30.5)	0.56 (14.3)	0.56 (14.2)	0.36 (9.1)	0.20 (5.1)	4500 (310)
3/8	6	9/16-18	-PHN-NS6-ST9	1.26 (32.0)	0.69 (17.5)	0.56 (14.2)	0.36 (9.1)	0.28 (7.1)	4500 (310)
1/2	8	3/4-16	-PHN-NS8-ST12	1.53 (38.9)	0.87 (22.2)	0.75 (19.1)	0.44 (11.2)	0.42 (10.7)	4500 (310)
3/4	12	1 1/16-12	-PHN-NS12-ST17	1.75 (44.4)	1.25 (31.8)	0.75 (19.1)	0.59 (15.0)	0.62 (15.7)	3600 (248)
1	16	1 5/16-12	-PHN-NS16-ST21	2.00 (50.8)	1.50 (38.1)	0.94 (23.9)	0.59 (15.0)	0.88 (22.4)	2900 (199)

Hex Nipples

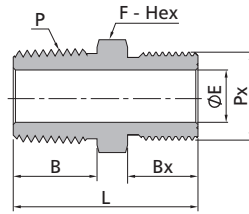

Pipe Fittings
Weld Fittings

Male NPT Threads			Male Metric Threads					
P-NPT Size	Px-Metric Size	Basic Ordering Number	Dimensions, mm (in.)					Working Pressure psig (bar) 316 SS, Steel
			L	F	B	Bx	E	
1/8	M20 x 1.5	-PHN-NS2-MS20	32.7 (1.29)	22.2 (0.87)	9.7 (0.38)	16.0 (0.63)	5.0 (0.20)	7700 (530)
1/4	M8 x 1	-PHN-NS4-MS8	29.0 (1.14)	14.3 (0.56)	14.2 (0.56)	9.0 (0.35)	3.2 (0.13)	8000 (551)
1/4	M14 x 1.5	-PHN-NS4-MS14	34.2 (1.35)	15.9 (0.63)	14.2 (0.56)	13.0 (0.51)	7.0 (0.28)	8000 (551)
1/4	M16 x 1.5	-PHN-NS4-MS16	35.2 (1.39)	17.5 (0.69)	14.2 (0.56)	14.0 (0.55)	7.1 (0.28)	7800 (537)
1/4	M20 x 1.5	-PHN-NS4-MS20	37.2 (1.46)	22.2 (0.87)	14.2 (0.56)	16.0 (0.63)	7.1 (0.28)	7700 (530)
3/8	M14 x 1.5	-PHN-NS6-MS14	34.2 (1.35)	17.5 (0.69)	14.2 (0.56)	13.0 (0.51)	7.0 (0.28)	7800 (537)
3/8	M20 x 1.5	-PHN-NS6-MS20	37.2 (1.46)	22.2 (0.87)	14.2 (0.56)	16.0 (0.63)	9.5 (0.37)	7700 (530)
3/8	M24 x 1.5	-PHN-NS6-MS24	38.2 (1.50)	25.4 (1.00)	14.2 (0.56)	17.0 (0.67)	9.5 (0.37)	7400 (509)
1/2	M14 x 1.5	-PHN-NS8-MS14	39.1 (1.54)	22.2 (0.87)	19.1 (0.75)	13.0 (0.51)	7.2 (0.28)	7700 (530)
1/2	M20 x 1.5	-PHN-NS8-MS20	42.0 (1.65)	22.2 (0.87)	19.1 (0.75)	16.0 (0.63)	10.0 (0.39)	7700 (530)
1/2	M24 x 1.5	-PHN-NS8-MS24	43.5 (1.71)	25.4 (1.00)	19.1 (0.75)	17.0 (0.67)	11.9 (0.47)	7400 (509)
3/4	M20 x 1.5	-PHN-NS12-MS20	42.1 (1.66)	27.0 (1.06)	19.1 (0.75)	16.0 (0.63)	10.8 (0.43)	7300 (502)
3/4	M27 x 2	-PHN-NS12-MS27	46.7 (1.84)	31.8 (1.25)	19.1 (0.75)	18.0 (0.71)	15.8 (0.62)	6100 (420)
1	M30 x 2	-PHN-NS16-MS30	56.3 (2.22)	34.9 (1.37)	23.9 (0.94)	20.0 (0.79)	19.4 (0.76)	6100 (420)

Male ISO Tapered Threads			Male Metric Threads					
P-RT Size	Px-Metric Size	Basic Ordering Number	Dimensions, mm (in.)					Working Pressure psig (bar) 316 SS, Steel
			L	F	B	Bx	E	
1/8	M20 x 1.5	-PHN-RT2-MS20	32.7 (1.29)	22.2 (0.87)	9.7 (0.38)	16.0 (0.63)	5.0 (0.20)	7700 (530)
1/4	M12 x 1.5	-PHN-RT4-MS12	33.4 (1.31)	14.3 (0.56)	14.2 (0.56)	12.0 (0.47)	6.0 (0.24)	8000 (551)
1/4	M20 x 1.5	-PHN-RT4-MS20	37.2 (1.46)	22.2 (0.87)	14.2 (0.56)	16.0 (0.63)	7.0 (0.28)	7700 (530)
3/8	M20 x 1.5	-PHN-RT6-MS20	37.2 (1.46)	22.2 (0.87)	14.2 (0.56)	16.0 (0.63)	9.5 (0.37)	7700 (530)
1/2	M20 x 1.5	-PHN-RT8-MS20	42.0 (1.65)	22.2 (0.87)	19.1 (0.75)	16.0 (0.63)	10.0 (0.39)	7700 (530)

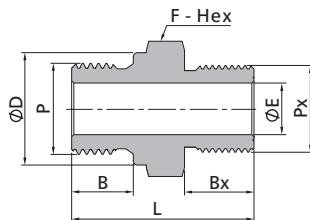

Male ISO Parallel Threads			Male Metric Threads						
P-RS Size	Px-Metric Size	Basic Ordering Number	Dimensions, mm (in.)						Working Pressure psig (bar) 316 SS, Steel
			L	F	B	Bx	E	D	
1/8	M20 x 1.5	-PHN-RS2-MS20	32.6 (1.28)	22.2 (0.87)	7.1 (0.28)	16.0 (0.63)	4.0 (0.16)	13.7 (0.54)	7700 (530)
1/4	M18 x 1.5	-PHN-RS4-MS18	34.2 (1.35)	20.6 (0.81)	11.2 (0.44)	15.0 (0.59)	5.9 (0.23)	18.0 (0.71)	7800 (537)
1/4	M20 x 1.5	-PHN-RS4-MS20	37.2 (1.46)	22.2 (0.87)	11.2 (0.44)	16.0 (0.63)	5.9 (0.23)	18.0 (0.71)	7700 (530)
3/8	M20 x 1.5	-PHN-RS6-MS20	37.2 (1.46)	22.2 (0.87)	11.2 (0.44)	16.0 (0.63)	7.9 (0.31)	21.6 (0.85)	7700 (530)
1/2	M20 x 1.5	-PHN-RS8-MS20	40.2 (1.58)	27.0 (1.06)	14.0 (0.55)	16.0 (0.63)	11.9 (0.47)	25.9 (1.02)	7700 (530)

Hex Nipples

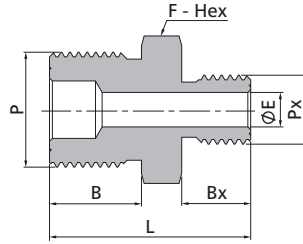

Male Metric Threads									
P-Metric Size	Px-Metric Size	Basic Ordering Number	Dimensions, mm (in.)					Working Pressure psig (bar) 316 SS, Steel	
			L	F	B	Bx	E		
M20 x 1.5	M10 x 1	-PHN-MS20-MS10	34.0 (1.34)	22.0 (0.87)	16.0 (0.63)	11.0 (0.43)	4.0 (0.16)	10000 (690)	
M20 x 1.5	M12 x 1.5	-PHN-MS20-MS12	35.0 (1.38)	22.0 (0.87)	16.0 (0.63)	12.0 (0.47)	6.0 (0.24)	9000 (620)	
M20 x 1.5	M14 x 1.5	-PHN-MS20-MS14	36.0 (1.42)	22.0 (0.87)	16.0 (0.63)	13.0 (0.51)	7.2 (0.28)	8000 (551)	
M20 x 1.5	M16 x 1.5	-PHN-MS20-MS16	37.0 (1.46)	22.0 (0.87)	16.0 (0.63)	14.0 (0.55)	9.0 (0.35)	7800 (537)	
M20 x 1.5	M20 x 1.5	-PHN-MS20	39.0 (1.54)	22.0 (0.87)	16.0 (0.63)	16.0 (0.63)	10.8 (0.43)	7700 (530)	
M27 x 2	M27 x 2	-PHN-MS27	44.5 (1.75)	30.0 (1.18)	18.0 (0.71)	18.0 (0.71)	16.1 (0.63)	7300 (502)	

Hex Long Nipples

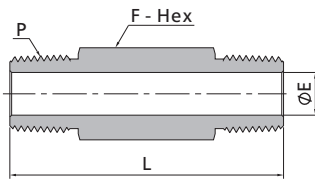

Male NPT Threads						
P-NPT Size	Basic Ordering Number	Dimensions, in. (mm)			Working Pressure psig (bar)	
		L	F	E	316 SS, Steel	Brass
1/8	-PLN-NS2-1.5	1.50 (38.1)	0.44 (11.1)	0.19 (4.8)	10000 (690)	5000 (344)
1/8	-PLN-NS2-2	2.00 (50.8)	0.44 (11.1)	0.19 (4.8)	10000 (690)	5000 (344)
1/8	-PLN-NS2-2.5	2.50 (63.5)	0.44 (11.1)	0.19 (4.8)	10000 (690)	5000 (344)
1/8	-PLN-NS2-3	3.00 (76.2)	0.44 (11.1)	0.19 (4.8)	10000 (690)	5000 (344)
1/4	-PLN-NS4-1.5	1.50 (38.1)	0.56 (14.3)	0.28 (7.1)	8000 (551)	4000 (275)
1/4	-PLN-NS4-2	2.00 (50.8)	0.56 (14.3)	0.28 (7.1)	8000 (551)	4000 (275)
1/4	-PLN-NS4-2.5	2.50 (63.5)	0.56 (14.3)	0.28 (7.1)	8000 (551)	4000 (275)
1/4	-PLN-NS4-3	3.00 (76.2)	0.56 (14.3)	0.28 (7.1)	8000 (551)	4000 (275)
1/4	-PLN-NS4-4	4.00 (101.6)	0.56 (14.3)	0.28 (7.1)	8000 (551)	4000 (275)
3/8	-PLN-NS6-1.5	1.50 (38.1)	0.69 (17.5)	0.38 (9.7)	7800 (537)	3900 (268)
3/8	-PLN-NS6-2	2.00 (50.8)	0.69 (17.5)	0.38 (9.7)	7800 (537)	3900 (268)
3/8	-PLN-NS6-2.5	2.50 (63.5)	0.69 (17.5)	0.38 (9.7)	7800 (537)	3900 (268)
3/8	-PLN-NS6-3	3.00 (76.2)	0.69 (17.5)	0.38 (9.7)	7800 (537)	3900 (268)
3/8	-PLN-NS6-4	4.00 (101.6)	0.69 (17.5)	0.38 (9.7)	7800 (537)	3900 (268)
1/2	-PLN-NS8-2	2.00 (50.8)	0.87 (22.2)	0.47 (11.9)	7700 (530)	3800 (261)
1/2	-PLN-NS8-3	3.00 (76.2)	0.87 (22.2)	0.47 (11.9)	7700 (530)	3800 (261)
1/2	-PLN-NS8-4	4.00 (101.6)	0.87 (22.2)	0.47 (11.9)	7700 (530)	3800 (261)
1/2	-PLN-NS8-6	6.00 (152.4)	0.87 (22.2)	0.47 (11.9)	7700 (530)	3800 (261)
3/4	-PLN-NS12-2	2.00 (50.8)	1.06 (27.0)	0.62 (15.7)	7300 (502)	3600 (248)
3/4	-PLN-NS12-3	3.00 (76.2)	1.06 (27.0)	0.62 (15.7)	7300 (502)	3600 (248)
3/4	-PLN-NS12-4	4.00 (101.6)	1.06 (27.0)	0.62 (15.7)	7300 (502)	3600 (248)
1	-PLN-NS16-3	3.00 (76.2)	1.37 (34.9)	0.88 (22.4)	5300 (365)	2600 (179)
1	-PLN-NS16-4	4.00 (101.6)	1.37 (34.9)	0.88 (22.4)	5300 (365)	2600 (179)

Hex Long Nipples

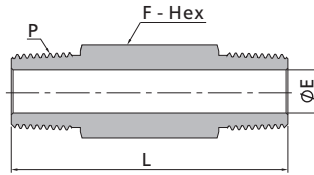

Male ISO Tapered Threads

P-RT Size	Basic Ordering Number	Dimensions, in. (mm)			Working Pressure psig (bar)	
		L	F	E	316 SS, Steel	Brass
1/8	-PLN-RT2-1.5	1.50 (38.1)	0.44 (11.1)	0.19 (4.8)	10000 (690)	5000 (344)
1/8	-PLN-RT2-2	2.00 (50.8)	0.44 (11.1)	0.19 (4.8)	10000 (690)	5000 (344)
1/8	-PLN-RT2-2.5	2.50 (63.5)	0.44 (11.1)	0.19 (4.8)	10000 (690)	5000 (344)
1/8	-PLN-RT2-3	3.00 (76.2)	0.44 (11.1)	0.19 (4.8)	10000 (690)	5000 (344)
1/4	-PLN-RT4-1.5	1.50 (38.1)	0.56 (14.3)	0.28 (7.1)	8000 (551)	4000 (275)
1/4	-PLN-RT4-2	2.00 (50.8)	0.56 (14.3)	0.28 (7.1)	8000 (551)	4000 (275)
1/4	-PLN-RT4-2.5	2.50 (63.5)	0.56 (14.3)	0.28 (7.1)	8000 (551)	4000 (275)
1/4	-PLN-RT4-3	3.00 (76.2)	0.56 (14.3)	0.28 (7.1)	8000 (551)	4000 (275)
1/4	-PLN-RT4-4	4.00 (101.6)	0.56 (14.3)	0.28 (7.1)	8000 (551)	4000 (275)
3/8	-PLN-RT6-1.5	1.50 (38.1)	0.69 (17.5)	0.38 (9.7)	7800 (537)	3900 (268)
3/8	-PLN-RT6-2	2.00 (50.8)	0.69 (17.5)	0.38 (9.7)	7800 (537)	3900 (268)
3/8	-PLN-RT6-2.5	2.50 (63.5)	0.69 (17.5)	0.38 (9.7)	7800 (537)	3900 (268)
3/8	-PLN-RT6-3	3.00 (76.2)	0.69 (17.5)	0.38 (9.7)	7800 (537)	3900 (268)
3/8	-PLN-RT6-4	4.00 (101.6)	0.69 (17.5)	0.38 (9.7)	7800 (537)	3900 (268)
1/2	-PLN-RT8-2	2.00 (50.8)	0.87 (22.2)	0.47 (11.9)	7700 (530)	3800 (261)
1/2	-PLN-RT8-3	3.00 (76.2)	0.87 (22.2)	0.47 (11.9)	7700 (530)	3800 (261)
1/2	-PLN-RT8-4	4.00 (101.6)	0.87 (22.2)	0.47 (11.9)	7700 (530)	3800 (261)
1/2	-PLN-RT8-6	6.00 (152.4)	0.87 (22.2)	0.47 (11.9)	7700 (530)	3800 (261)
3/4	-PLN-RT12-2	2.00 (50.8)	1.06 (27.0)	0.62 (15.7)	7300 (502)	3600 (248)
3/4	-PLN-RT12-3	3.00 (76.2)	1.06 (27.0)	0.62 (15.7)	7300 (502)	3600 (248)
3/4	-PLN-RT12-4	4.00 (101.6)	1.06 (27.0)	0.62 (15.7)	7300 (502)	3600 (248)
1	-PLN-RT16-3	3.00 (76.2)	1.37 (34.9)	0.88 (22.4)	5300 (365)	2600 (179)
1	-PLN-RT16-4	4.00 (101.6)	1.37 (34.9)	0.88 (22.4)	5300 (365)	2600 (179)

Close Nipples

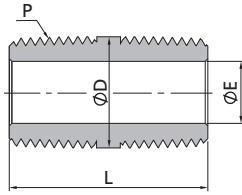

Pipe Fittings
Weld Fittings

Male NPT Threads						
P-NPT Size	Basic Ordering Number	Dimensions, in. (mm)			Working Pressure psig (bar)	
		L	D	E	316 SS, Steel	Brass
1/16	-PCN-NS1	0.75 (19.1)	0.31 (7.9)	0.12 (3.0)	11000 (757)	5500 (378)
1/8	-PCN-NS2	0.75 (19.1)	0.41 (10.3)	0.19 (4.8)	10000 (690)	5000 (344)
1/4	-PCN-NS4	1.12 (28.4)	0.54 (13.7)	0.28 (7.1)	8000 (551)	4000 (275)
3/8	-PCN-NS6	1.12 (28.4)	0.67 (17.1)	0.38 (9.6)	7800 (537)	3900 (268)
1/2	-PCN-NS8	1.50 (38.1)	0.84 (21.3)	0.47 (11.9)	7700 (530)	3800 (261)
3/4	-PCN-NS12	1.50 (38.1)	1.05 (26.7)	0.62 (15.7)	7300 (502)	3600 (248)
1	-PCN-NS16	1.88 (47.8)	1.31 (33.4)	0.88 (22.4)	5300 (365)	2600 (179)

Male ISO Tapered Threads						
P-RT Size	Basic Ordering Number	Dimensions, in. (mm)			Working Pressure psig (bar)	
		L	D	E	316 SS, Steel	Brass
1/16	-PCN-RT1	0.75 (19.1)	0.31 (7.9)	0.12 (3.0)	11000 (757)	5500 (378)
1/8	-PCN-RT2	0.75 (19.1)	0.41 (10.3)	0.19 (4.8)	10000 (690)	5000 (344)
1/4	-PCN-RT4	1.12 (28.4)	0.54 (13.7)	0.28 (7.1)	8000 (551)	4000 (275)
3/8	-PCN-RT6	1.12 (28.4)	0.67 (17.1)	0.38 (9.7)	7800 (537)	3900 (268)
1/2	-PCN-RT8	1.50 (38.1)	0.84 (21.3)	0.47 (11.9)	7700 (530)	3800 (261)
3/4	-PCN-RT12	1.50 (38.1)	1.05 (26.7)	0.62 (15.7)	7300 (502)	3600 (248)
1	-PCN-RT16	1.88 (47.8)	1.31 (33.4)	0.88 (22.4)	5300 (365)	2600 (179)

Special Pipe Nipples

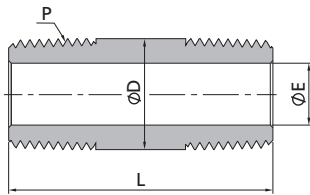

Male NPT Threads						
P-NPT Size	Basic Ordering Number	Dimensions, in. (mm)			Working Pressure psig (bar)	
		L	D	E	316 SS, Steel	Brass
1/8	-PSN-NS2-1.5	1.50 (38.1)	0.41 (10.3)	0.19 (4.8)	10000 (690)	5000 (344)
1/8	-PSN-NS2-2	2.00 (50.8)	0.41 (10.3)	0.19 (4.8)	10000 (690)	5000 (344)
1/8	-PSN-NS2-2.5	2.50 (63.5)	0.41 (10.3)	0.19 (4.8)	10000 (690)	5000 (344)
1/8	-PSN-NS2-3	3.00 (76.2)	0.41 (10.3)	0.19 (4.8)	10000 (690)	5000 (344)
1/4	-PSN-NS4-1.5	1.50 (38.1)	0.54 (13.7)	0.28 (7.1)	8000 (551)	4000 (275)
1/4	-PSN-NS4-2	2.00 (50.8)	0.54 (13.7)	0.28 (7.1)	8000 (551)	4000 (275)
1/4	-PSN-NS4-2.5	2.50 (63.5)	0.54 (13.7)	0.28 (7.1)	8000 (551)	4000 (275)
1/4	-PSN-NS4-3	3.00 (76.2)	0.54 (13.7)	0.28 (7.1)	8000 (551)	4000 (275)
1/4	-PSN-NS4-4	4.00 (101.6)	0.54 (13.7)	0.28 (7.1)	8000 (551)	4000 (275)
3/8	-PSN-NS6-1.5	1.50 (38.1)	0.67 (17.1)	0.38 (9.7)	7800 (537)	3900 (268)
3/8	-PSN-NS6-2	2.00 (50.8)	0.67 (17.1)	0.38 (9.7)	7800 (537)	3900 (268)
3/8	-PSN-NS6-2.5	2.50 (63.5)	0.67 (17.1)	0.38 (9.7)	7800 (537)	3900 (268)
3/8	-PSN-NS6-3	3.00 (76.2)	0.67 (17.1)	0.38 (9.7)	7800 (537)	3900 (268)
3/8	-PSN-NS6-4	4.00 (101.6)	0.67 (17.1)	0.38 (9.7)	7800 (537)	3900 (268)
1/2	-PSN-NS8-2	2.00 (50.8)	0.84 (21.3)	0.47 (11.9)	7700 (530)	3800 (261)
1/2	-PSN-NS8-3	3.00 (76.2)	0.84 (21.3)	0.47 (11.9)	7700 (530)	3800 (261)
1/2	-PSN-NS8-4	4.00 (101.6)	0.84 (21.3)	0.47 (11.9)	7700 (530)	3800 (261)
1/2	-PSN-NS8-6	6.00 (152.4)	0.84 (21.3)	0.47 (11.9)	7700 (530)	3800 (261)
3/4	-PSN-NS12-2	2.00 (50.8)	1.05 (26.7)	0.62 (15.7)	7300 (502)	3600 (248)
3/4	-PSN-NS12-3	3.00 (76.2)	1.05 (26.7)	0.62 (15.7)	7300 (502)	3600 (248)
3/4	-PSN-NS12-4	4.00 (101.6)	1.05 (26.7)	0.62 (15.7)	7300 (502)	3600 (248)
1	-PSN-NS16-3	3.00 (76.2)	1.31 (33.4)	0.88 (22.4)	5300 (365)	2600 (179)
1	-PSN-NS16-4	4.00 (101.6)	1.31 (33.4)	0.88 (22.4)	5300 (365)	2600 (179)

Adapters

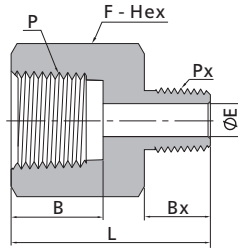

Pipe Fittings
Weld Fittings

Female NPT Threads			Male NPT Threads						
P-NPT Size	Px-NPT Size	Basic Ordering Number	Dimensions, in. (mm)					Working Pressure psig (bar)	
			L	F	B	Bx	E	316 SS, Steel	Brass
1/8	1/16	-PA-NS2-NS1	1.09 (27.7)	0.56 (14.3)	0.41 (10.4)	0.38 (9.7)	0.12 (3.0)	6500 (447)	3200 (220)
1/8	1/8	-PA-NS2	1.10 (27.9)	0.56 (14.3)	0.41 (10.4)	0.38 (9.7)	0.19 (4.8)	6500 (447)	3200 (220)
1/4	1/16	-PA-NS4-NS1	1.20 (30.5)	0.75 (19.1)	0.59 (15.0)	0.38 (9.7)	0.12 (3.0)	6600 (454)	3300 (227)
1/4	1/8	-PA-NS4-NS2	1.26 (32.0)	0.75 (19.1)	0.59 (15.0)	0.38 (9.7)	0.19 (4.8)	6600 (454)	3300 (227)
1/4	1/4	-PA-NS4	1.40 (35.6)	0.75 (19.1)	0.59 (15.0)	0.56 (14.2)	0.28 (7.1)	6600 (454)	3300 (227)
3/8	1/16	-PA-NS6-NS1	1.25 (31.8)	0.87 (22.2)	0.59 (15.0)	0.38 (9.7)	0.12 (3.0)	5300 (365)	2600 (179)
3/8	1/8	-PA-NS6-NS2	1.33 (33.8)	0.87 (22.2)	0.59 (15.0)	0.38 (9.7)	0.19 (4.8)	5300 (365)	2600 (179)
3/8	1/4	-PA-NS6-NS4	1.50 (38.1)	0.87 (22.2)	0.59 (15.0)	0.56 (14.2)	0.28 (7.1)	5300 (365)	2600 (179)
3/8	3/8	-PA-NS6	1.51 (38.4)	0.87 (22.2)	0.59 (15.0)	0.56 (14.2)	0.38 (9.6)	5300 (365)	2600 (179)
1/2	1/8	-PA-NS8-NS2	1.58 (40.1)	1.06 (27.0)	0.78 (19.8)	0.38 (9.7)	0.19 (4.8)	4900 (337)	2400 (165)
1/2	1/4	-PA-NS8-NS4	1.76 (44.7)	1.06 (27.0)	0.78 (19.8)	0.56 (14.2)	0.28 (7.1)	4900 (337)	2400 (165)
1/2	3/8	-PA-NS8-NS6	1.75 (44.4)	1.06 (27.0)	0.78 (19.8)	0.56 (14.2)	0.38 (9.6)	4900 (337)	2400 (165)
1/2	1/2	-PA-NS8	1.94 (49.3)	1.06 (27.0)	0.78 (19.8)	0.75 (19.1)	0.47 (11.9)	4900 (337)	2400 (165)
3/4	1/8	-PA-NS12-NS2	1.56 (39.6)	1.31 (33.3)	0.81 (20.6)	0.38 (9.7)	0.19 (4.8)	4600 (316)	2300 (158)
3/4	1/4	-PA-NS12-NS4	1.85 (47.0)	1.31 (33.3)	0.81 (20.6)	0.56 (14.2)	0.28 (7.1)	4600 (316)	2300 (158)
3/4	3/8	-PA-NS12-NS6	1.82 (46.2)	1.31 (33.3)	0.81 (20.6)	0.56 (14.2)	0.38 (9.6)	4600 (316)	2300 (158)
3/4	1/2	-PA-NS12-NS8	2.02 (51.3)	1.31 (33.3)	0.81 (20.6)	0.75 (19.1)	0.47 (11.9)	4600 (316)	2300 (158)
3/4	3/4	-PA-NS12	2.02 (51.3)	1.31 (33.3)	0.81 (20.6)	0.75 (19.1)	0.62 (15.7)	4600 (316)	2300 (158)
1	1/8	-PA-NS16-NS2	1.81 (46.0)	1.63 (41.3)	1.00 (25.4)	0.38 (9.7)	0.19 (4.8)	4400 (303)	2200 (151)
1	1/4	-PA-NS16-NS4	1.96 (49.8)	1.63 (41.3)	1.00 (25.4)	0.56 (14.2)	0.28 (7.1)	4400 (303)	2200 (151)
1	3/8	-PA-NS16-NS6	2.00 (50.8)	1.63 (41.3)	1.00 (25.4)	0.56 (14.2)	0.38 (9.6)	4400 (303)	2200 (151)
1	1/2	-PA-NS16-NS8	2.16 (54.9)	1.63 (41.3)	1.00 (25.4)	0.75 (19.1)	0.47 (11.9)	4400 (303)	2200 (151)
1	3/4	-PA-NS16-NS12	2.17 (55.1)	1.63 (41.3)	1.00 (25.4)	0.75 (19.1)	0.62 (15.7)	4400 (303)	2200 (151)
1	1	-PA-NS16	2.28 (57.9)	1.63 (41.3)	1.00 (25.4)	0.94 (23.9)	0.88 (22.4)	4400 (303)	2200 (151)
1 1/4	1	-PA-NS20-NS16	2.47 (62.7)	2.13 (54.0)	1.00 (25.4)	0.94 (23.9)	0.88 (22.4)	5000 (344)	2500 (172)

Adapters

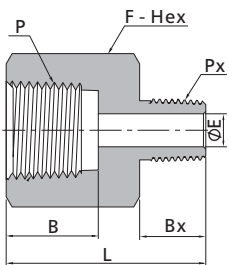

Female NPT Threads			Male ISO Tapered Threads						
P-NPT Size	Px-RT Size	Basic Ordering Number	Dimensions, in. (mm)					Working Pressure psig (bar)	
			L	F	B	Bx	E	316 SS, Steel	Brass
1/8	1/8	-PA-NS2-RT2	1.09 (27.7)	0.56 (14.3)	0.41 (10.4)	0.38 (9.7)	0.19 (4.8)	6500 (447)	3200 (220)
1/4	1/4	-PA-NS4-RT4	1.42 (36.1)	0.75 (19.1)	0.59 (15.0)	0.56 (14.2)	0.28 (7.1)	6600 (454)	3300 (227)
3/8	3/8	-PA-NS6-RT6	1.50 (38.1)	0.87 (22.2)	0.59 (15.0)	0.56 (14.2)	0.38 (9.6)	5300 (365)	2600 (179)
1/2	1/2	-PA-NS8-RT8	1.94 (49.3)	1.06 (27.0)	0.78 (19.8)	0.75 (19.1)	0.47 (11.9)	4900 (337)	2400 (165)
3/4	3/4	-PA-NS12-RT12	2.02 (51.3)	1.31 (33.3)	0.81 (20.6)	0.75 (19.1)	0.62 (15.7)	4600 (316)	2300 (158)
1	1	-PA-NS16-RT16	2.30 (58.4)	1.63 (41.3)	1.00 (25.4)	0.94 (23.9)	0.88 (22.4)	4400 (303)	2200 (151)

Adapters

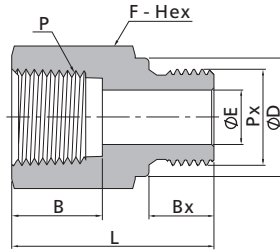

Female NPT Threads			Male ISO Parallel Threads							
P-NPT Size	Px-RS Size	Basic Ordering Number	Dimensions, in. (mm)						Working Pressure psig (bar)	
			L	F	B	Bx	D	E	316 SS, Steel	Brass
1/8	1/8	-PA-NS2-RS2	0.99 (25.1)	0.56 (14.3)	0.41 (10.4)	0.28 (7.1)	0.54 (13.7)	0.16 (4.1)	6500 (447)	3200 (220)
1/4	1/4	-PA-NS4-RS4	1.32 (33.5)	0.75 (19.1)	0.41 (10.4)	0.44 (11.2)	0.71 (18.0)	0.23 (5.8)	6600 (454)	3300 (227)
3/8	3/8	-PA-NS6-RS6	1.41 (35.8)	0.87 (22.2)	0.59 (15.0)	0.44 (11.2)	0.85 (21.6)	0.31 (7.9)	5300 (365)	2600 (179)
1/2	1/2	-PA-NS8-RS8	1.74 (44.2)	1.06 (27.0)	0.59 (15.0)	0.56 (14.2)	1.02 (25.9)	0.47 (11.9)	4900 (337)	2400 (165)
3/4	3/4	-PA-NS12-RS12	1.89 (48.0)	1.31 (33.3)	0.81 (20.6)	0.62 (15.7)	1.26 (32.0)	0.62 (15.7)	4600 (316)	2300 (158)
1	1	-PA-NS16-RS16	2.10 (53.3)	1.63 (41.3)	1.00 (25.4)	0.72 (18.3)	1.53 (38.9)	0.78 (19.8)	4400 (303)	2200 (151)

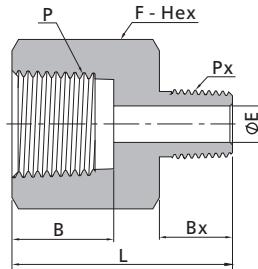

Female ISO Tapered Threads			Male ISO Tapered Threads						
P-RT Size	Px-RT Size	Basic Ordering Number	Dimensions, in. (mm)					Working Pressure psig (bar)	
			L	F	B	Bx	E	316 SS, Steel	Brass
1/8	1/8	-PA-RT2	1.09 (27.7)	0.56 (14.3)	0.41 (10.4)	0.38 (9.7)	0.19 (4.8)	6500 (447)	3200 (220)
1/4	1/8	-PA-RT4-RT2	1.26 (32.0)	0.75 (19.1)	0.59 (15.0)	0.38 (9.7)	0.19 (4.8)	6600 (454)	3300 (227)
1/4	1/4	-PA-RT4	1.42 (36.1)	0.75 (19.1)	0.59 (15.0)	0.56 (14.2)	0.28 (7.1)	6600 (454)	3300 (227)
3/8	1/4	-PA-RT6-RT4	1.50 (38.1)	0.87 (22.2)	0.59 (15.0)	0.56 (14.2)	0.28 (7.1)	5300 (365)	2600 (179)
3/8	3/8	-PA-RT6	1.50 (38.1)	0.87 (22.2)	0.59 (15.0)	0.56 (14.2)	0.38 (9.7)	5300 (365)	2600 (179)
1/2	1/4	-PA-RT8-RT4	1.76 (44.7)	1.06 (27.0)	0.78 (19.8)	0.56 (14.2)	0.28 (7.1)	4900 (337)	2400 (165)
1/2	3/8	-PA-RT8-RT6	1.75 (44.4)	1.06 (27.0)	0.78 (19.8)	0.56 (14.2)	0.38 (9.7)	4900 (337)	2400 (165)
1/2	1/2	-PA-RT8	1.95 (49.5)	1.06 (27.0)	0.78 (19.8)	0.75 (19.1)	0.47 (11.9)	4900 (337)	2400 (165)
3/4	3/4	-PA-RT12	2.02 (51.3)	1.31 (33.3)	0.81 (20.6)	0.75 (19.1)	0.62 (15.7)	4600 (316)	2300 (158)
1	1	-PA-RT16	2.30 (58.4)	1.63 (41.3)	1.00 (25.4)	0.94 (23.9)	0.88 (22.4)	4400 (303)	2200 (151)

Adapters

Pipe Fittings
Weld Fittings

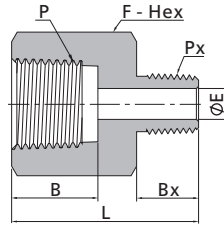

Female ISO Tapered Threads			Male NPT Threads						
P-RT Size	Px-NPT Size	Basic Ordering Number	Dimensions, in. (mm)					Working Pressure psig (bar)	
			L	F	B	Bx	E	316 SS, Steel	Brass
1/8	1/8	-PA-RT2-NS2	1.09 (27.7)	0.56 (14.3)	0.41 (10.4)	0.38 (9.7)	0.19 (4.8)	6500 (447)	3200 (220)
1/4	1/4	-PA-RT4-NS4	1.43 (36.3)	0.75 (19.1)	0.59 (15.0)	0.56 (14.2)	0.28 (7.1)	6600 (454)	3300 (227)
3/8	3/8	-PA-RT6-NS6	1.51 (38.4)	0.87 (22.2)	0.59 (15.0)	0.56 (14.2)	0.38 (9.6)	5300 (365)	2600 (179)
1/2	1/2	-PA-RT8-NS8	1.96 (49.8)	1.06 (27.0)	0.78 (19.8)	0.75 (19.1)	0.47 (11.9)	4900 (337)	2400 (165)
3/4	3/4	-PA-RT12-NS12	2.02 (51.3)	1.31 (33.3)	0.81 (20.6)	0.75 (19.1)	0.62 (15.7)	4600 (316)	2300 (158)
1	1	-PA-RT16-NS16	2.30 (58.4)	1.63 (41.3)	1.00 (25.4)	0.94 (23.9)	0.88 (22.4)	4400 (303)	2200 (151)

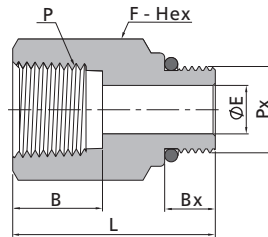

Female NPT Threads				Male SAE/MS Straight Threads (ST)					
P-NPT Size	Px-SAE Nominal Size	Px-SAE/MS Thread Specification	Basic Ordering Number	Dimensions, in. (mm)					Working Pressure psig (bar) 316 SS, Steel
				L	F	B	Bx	E	
1/4	4	7/16-20	-PA-NS4-ST7	1.32 (33.5)	0.75 (19.1)	0.59 (15.0)	0.36 (9.1)	0.20 (5.1)	4500 (310)
3/8	6	9/16-18	-PA-NS6-ST9	1.39 (35.3)	0.94 (23.8)	0.59 (15.0)	0.39 (9.9)	0.28 (7.1)	4500 (310)
1/2	8	3/4-16	-PA-NS8-ST12	1.76 (44.7)	1.06 (27.0)	0.78 (19.8)	0.44 (11.2)	0.42 (10.7)	4500 (310)
3/4	12	1 1/16-12	-PA-NS12-ST17	1.99 (50.5)	1.37 (34.9)	0.81 (20.6)	0.59 (15.0)	0.66 (16.8)	3600 (248)
1	16	1 5/16-12	-PA-NS16-ST21	2.12 (53.8)	1.63 (41.3)	1.00 (25.4)	0.59 (15.0)	0.85 (21.5)	2900 (199)

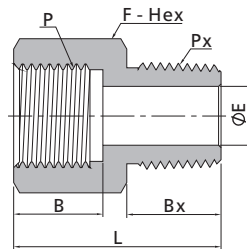

Female ISO Parallel Threads			Male NPT Threads					
P-RG Size	Px-NPT Size	Basic Ordering Number	Dimensions, in. (mm)					Working Pressure psig (bar) 316 SS, Steel
			L	F	B	Bx	E	
1/8	1/8	-PA-RG2-NS2	0.86 (21.8)	0.56 (14.3)	0.26 (6.5)	0.38 (9.7)	0.18 (4.5)	6100 (420)
1/4	1/4	-PA-RG4-NS4	1.19 (30.2)	0.75 (19.1)	0.51 (12.9)	0.56 (14.2)	0.22 (5.5)	5700 (392)
3/8	3/8	-PA-RG6-NS6	1.27 (32.2)	0.94 (23.8)	0.56 (14.2)	0.56 (14.2)	0.26 (6.5)	5700 (392)
1/2	1/2	-PA-RG8-NS8	1.68 (42.7)	1.06 (27.0)	0.74 (18.8)	0.75 (19.1)	0.28 (7.0)	3900 (268)

Reducing Bushings

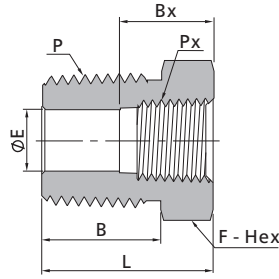

Male NPT Threads			Dimensions, in. (mm)							Female NPT Threads	
P-NPT Size	Px-NPT Size	Basic Ordering Number	L	F	B	Bx	E	Working Pressure psig (bar)			
								316 SS, Steel	Brass		
1/8	1/16	-PRB-NS2-NS1	1.03 (26.2)	0.44 (11.1)	0.38 (9.7)	0.39 (9.9)	0.19 (4.8)	6500 (447)	3200 (220)		
1/4	1/16	-PRB-NS4-NS1	0.86 (21.8)	0.56 (14.3)	0.56 (14.2)	0.39 (9.9)	0.19 (4.8)	8000 (551)	4000 (275)		
1/4	1/8	-PRB-NS4-NS2	1.06 (26.9)	0.56 (14.3)	0.56 (14.2)	0.41 (10.4)	0.28 (7.1)	6500 (447)	3300 (227)		
3/8	1/16	-PRB-NS6-NS1	0.86 (21.8)	0.69 (17.5)	0.56 (14.2)	0.39 (9.9)	0.19 (4.8)	7800 (537)	3900 (268)		
3/8	1/8	-PRB-NS6-NS2	0.86 (21.8)	0.69 (17.5)	0.56 (14.2)	0.41 (10.4)	0.34 (8.6)	7800 (537)	3900 (268)		
3/8	1/4	-PRB-NS6-NS4	1.19 (30.2)	0.75 (19.1)	0.56 (14.2)	0.59 (15.0)	0.38 (9.6)	6600 (454)	3300 (227)		
1/2	1/8	-PRB-NS8-NS2	1.08 (27.4)	0.87 (22.2)	0.75 (19.1)	0.41 (10.4)	0.34 (8.6)	8300 (571)	4400 (303)		
1/2	1/4	-PRB-NS8-NS4	1.08 (27.4)	0.87 (22.2)	0.75 (19.1)	0.59 (15.0)	0.45 (11.4)	8300 (571)	4400 (303)		
1/2	3/8	-PRB-NS8-NS6	1.41 (35.8)	0.87 (22.2)	0.75 (19.1)	0.59 (15.0)	0.47 (11.9)	5300 (365)	2600 (179)		
3/4	1/4	-PRB-NS12-NS4	1.08 (27.4)	1.06 (27.0)	0.75 (19.1)	0.59 (15.0)	0.45 (11.4)	7300 (502)	3600 (248)		
3/4	3/8	-PRB-NS12-NS6	1.08 (27.4)	1.06 (27.0)	0.75 (19.1)	0.59 (15.0)	0.59 (15.0)	7300 (502)	3600 (248)		
3/4	1/2	-PRB-NS12-NS8	1.63 (41.4)	1.06 (27.0)	0.75 (19.1)	0.78 (19.8)	0.62 (15.7)	4900 (337)	2400 (165)		
1	1/4	-PRB-NS16-NS4	1.37 (34.8)	1.37 (34.9)	0.94 (23.9)	0.59 (15.0)	0.45 (11.4)	6500 (447)	3200 (220)		
1	3/8	-PRB-NS16-NS6	1.37 (34.8)	1.37 (34.9)	0.94 (23.9)	0.59 (15.0)	0.59 (15.0)	6500 (447)	3200 (220)		
1	1/2	-PRB-NS16-NS8	1.37 (34.8)	1.37 (34.9)	0.94 (23.9)	0.78 (19.8)	0.73 (18.5)	6500 (447)	3200 (220)		
1	3/4	-PRB-NS16-NS12	1.85 (47.0)	1.37 (34.9)	0.94 (23.9)	0.81 (20.6)	0.88 (22.4)	5300 (365)	2600 (179)		
1 1/4	3/4	-PRB-NS20-NS12	1.47 (37.3)	1.75 (44.5)	0.94 (23.9)	0.81 (20.6)	0.88 (22.4)	6000 (410)	3000 (205)		
1 1/4	1	-PRB-NS20-NS16	1.47 (37.3)	1.75 (44.5)	0.94 (23.9)	1.00 (25.4)	0.88 (22.4)	3500 (241)	1750 (120)		
1 1/2	1	-PRB-NS24-NS16	1.58 (40.1)	2.00 (50.8)	1.03 (26.2)	1.00 (25.4)	0.88 (22.4)	5000 (344)	2500 (172)		
1 1/2	1 1/4	-PRB-NS24-NS20	2.20 (56.0)	2.13 (54.0)	1.03 (26.2)	1.00 (25.4)	1.34 (34.0)	5000 (344)	2500 (172)		

Reducing Bushings

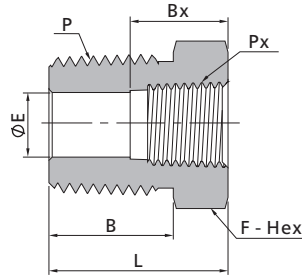

Pipe Fittings
Weld Fittings

Male NPT Threads			Female ISO Tapered Threads							
P-NPT Size	Px-RT Size	Basic Ordering Number	Dimensions, in. (mm)					Working Pressure psig (bar)		
			L	F	B	Bx	E	316 SS, Steel	Brass	
1/8	1/16	-PRB-NS2-RT1	1.03 (26.2)	0.44 (11.1)	0.38 (9.7)	0.39 (9.9)	0.19 (4.8)	6500 (447)	3200 (220)	
1/4	1/16	-PRB-NS4-RT1	0.86 (21.8)	0.56 (14.3)	0.56 (14.2)	0.39 (9.9)	0.19 (4.8)	8000 (551)	4000 (275)	
1/4	1/8	-PRB-NS4-RT2	1.06 (26.9)	0.56 (14.3)	0.56 (14.2)	0.41 (10.4)	0.28 (7.1)	6500 (447)	3300 (227)	
3/8	1/16	-PRB-NS6-RT1	0.86 (21.8)	0.69 (17.5)	0.56 (14.2)	0.39 (9.9)	0.19 (4.8)	7800 (537)	3900 (268)	
3/8	1/8	-PRB-NS6-RT2	0.86 (21.8)	0.69 (17.5)	0.56 (14.2)	0.41 (10.4)	0.28 (7.1)	7800 (537)	3900 (268)	
3/8	1/4	-PRB-NS6-RT4	1.19 (30.2)	0.75 (19.1)	0.56 (14.2)	0.59 (15.0)	0.38 (9.7)	6600 (454)	3300 (227)	
1/2	1/8	-PRB-NS8-RT2	1.08 (27.4)	0.87 (22.2)	0.75 (19.1)	0.41 (10.4)	0.28 (7.1)	8300 (571)	4400 (303)	
1/2	1/4	-PRB-NS8-RT4	1.08 (27.4)	0.87 (22.2)	0.75 (19.1)	0.59 (15.0)	0.41 (10.4)	8300 (571)	4400 (303)	
1/2	3/8	-PRB-NS8-RT6	1.41 (35.8)	0.87 (22.2)	0.75 (19.1)	0.59 (15.0)	0.47 (11.9)	5300 (365)	2600 (179)	
3/4	1/4	-PRB-NS12-RT4	1.08 (27.4)	1.06 (27.0)	0.75 (19.1)	0.59 (15.0)	0.41 (10.4)	7300 (502)	3600 (248)	
3/4	3/8	-PRB-NS12-RT6	1.08 (27.4)	1.06 (27.0)	0.75 (19.1)	0.59 (15.0)	0.50 (12.7)	7300 (502)	3600 (248)	
3/4	1/2	-PRB-NS12-RT8	1.63 (41.4)	1.06 (27.0)	0.75 (19.1)	0.78 (19.8)	0.62 (15.7)	4900 (337)	2400 (165)	
1	1/4	-PRB-NS16-RT4	1.37 (34.8)	1.37 (34.9)	0.94 (23.9)	0.59 (15.0)	0.41 (10.4)	6500 (447)	3200 (220)	
1	3/8	-PRB-NS16-RT6	1.37 (34.8)	1.37 (34.9)	0.94 (23.9)	0.59 (15.0)	0.50 (12.7)	6500 (447)	3200 (220)	
1	1/2	-PRB-NS16-RT8	1.37 (34.8)	1.37 (34.9)	0.94 (23.9)	0.78 (19.8)	0.62 (15.7)	6500 (447)	3200 (220)	
1	3/4	-PRB-NS16-RT12	1.85 (47.0)	1.37 (34.9)	0.94 (23.9)	0.81 (20.6)	0.88 (22.4)	5300 (365)	2600 (179)	
1 1/4	3/4	-PRB-NS20-RT12	1.47 (37.3)	1.75 (44.5)	0.94 (23.9)	0.81 (20.6)	0.88 (22.4)	6000 (410)	3000 (205)	
1 1/4	1	-PRB-NS20-RT16	1.47 (37.3)	1.75 (44.5)	0.94 (23.9)	1.00 (25.4)	0.88 (22.4)	3500 (241)	1750 (120)	
1 1/2	1	-PRB-NS24-RT16	1.58 (40.1)	2.00 (50.8)	1.03 (26.2)	1.00 (25.4)	0.88 (22.4)	5000 (344)	2500 (172)	
1 1/2	1 1/4	-PRB-NS24-RT20	2.20 (56.0)	2.13 (54.0)	1.03 (26.2)	1.00 (25.4)	1.34 (34.0)	5000 (344)	2500 (172)	

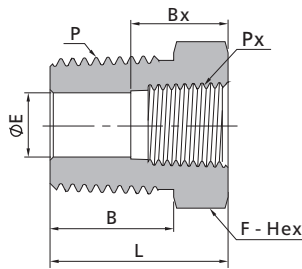

Male ISO Tapered Threads			Female ISO Tapered Threads							
P-RT Size	Px-RT Size	Basic Ordering Number	Dimensions, in. (mm)					Working Pressure psig (bar)		
			L	F	B	Bx	E	316 SS, Steel	Brass	
1/4	1/8	-PRB-RT4-RT2	1.06 (26.9)	0.56 (14.3)	0.56 (14.2)	0.41 (10.4)	0.28 (7.1)	6500 (447)	3200 (220)	
3/8	1/4	-PRB-RT6-RT4	1.19 (30.2)	0.75 (19.1)	0.56 (14.2)	0.59 (15.0)	0.38 (9.6)	6600 (454)	3300 (227)	
1/2	1/4	-PRB-RT8-RT4	1.08 (27.4)	0.87 (22.2)	0.75 (19.1)	0.59 (15.0)	0.44 (11.2)	8300 (571)	4400 (303)	
1/2	3/8	-PRB-RT8-RT6	1.41 (35.8)	0.87 (22.2)	0.75 (19.1)	0.59 (15.0)	0.47 (11.9)	5300 (365)	2600 (179)	

Reducing Bushings

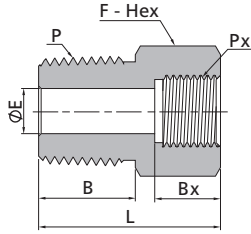

Male NPT Threads			Female ISO Parallel Threads					
P-NPT Size	Px-RG Size	Basic Ordering Number	Dimensions, in. (mm)					Working Pressure psig (bar) 316 SS, Steel
			L	F	B	Bx	E	
3/8	1/4	-PRB-NS6-RG4	1.19 (30.2)	0.75 (19.1)	0.56 (14.2)	0.51 (12.9)	0.22 (5.6)	5700 (392)
1/2	3/8	-PRB-NS8-RG6	1.41 (35.8)	0.87 (22.2)	0.75 (19.1)	0.56 (14.2)	0.26 (6.6)	5700 (392)
3/4	1/2	-PRB-NS12-RG8	1.63 (41.4)	1.06 (27.0)	0.75 (19.1)	0.74 (18.8)	0.28 (7.1)	3900 (268)

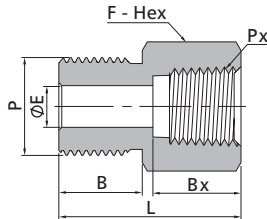

Male ISO Parallel Threads			Female NPT Threads						
P-BP Size	Px-NPT Size	Basic Ordering Number	Dimensions, in. (mm)					Working Pressure psig (bar)	
			L	F	B	Bx	E	316 SS, Steel	Brass
1/4	1/8	-PRB-BP4-NS2	1.06 (26.9)	0.56 (14.3)	0.51 (12.9)	0.41 (10.4)	0.18 (4.5)	6500 (447)	3200 (220)
3/8	1/4	-PRB-BP6-NS4	1.22 (31.0)	0.75 (19.1)	0.56 (14.2)	0.59 (15.0)	0.28 (7.1)	6600 (454)	3300 (227)
1/2	3/8	-PRB-BP8-NS6	1.41 (35.8)	0.87 (22.2)	0.74 (18.8)	0.59 (15.0)	0.26 (6.6)	5300 (365)	2600 (179)

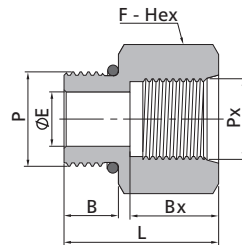

Male SAE/MS Straight Threads (ST)					Female SAE/MS Straight Threads					
P-SAE Nominal Size	P-SAE/MS Thread Specification	Px-SAE Nominal Size	Px-SAE/MS Thread Specification	Basic Ordering Number	Dimensions, in. (mm)					Working Pressure psig (bar) 316 SS, Steel
					L	F	B	Bx	E	
6	9/16-18	4	7/16-20	-PRB-ST9-US7	1.12 (28.4)	0.81 (20.6)	0.39 (9.9)	0.55 (14.0)	0.28 (7.1)	4500 (310)
8	3/4-16	4	7/16-20	-PRB-ST12-US7	0.98 (24.9)	0.87 (22.2)	0.44 (11.2)	0.55 (14.0)	0.39 (9.9)	4500 (310)
8	3/4-16	6	9/16-18	-PRB-ST12-US9	1.19 (30.2)	1.00 (25.4)	0.44 (11.2)	0.63 (16.0)	0.42 (10.7)	4500 (310)
10	7/8-14	6	9/16-18	-PRB-ST14-US9	1.10 (27.9)	1.00 (25.4)	0.50 (12.7)	0.63 (16.0)	0.50 (12.7)	3600 (248)
10	7/8-14	8	3/4-16	-PRB-ST14-US12	1.42 (36.1)	1.19 (30.2)	0.50 (12.7)	0.71 (18.0)	0.50 (12.7)	3600 (248)
12	1 1/16-12	8	3/4-16	-PRB-ST17-US12	1.27 (32.3)	1.25 (31.8)	0.59 (15.0)	0.71 (18.0)	0.65 (16.5)	3600 (248)
16	1 5/16-12	12	1 1/16-12	-PRB-ST21-US17	1.61 (40.9)	1.63 (41.3)	0.59 (15.0)	0.94 (24.0)	0.87 (22.1)	2900 (199)
20	1 5/8-12	16	1 5/16-12	-PRB-ST26-US21	1.98 (50.3)	2.13 (54.0)	0.59 (15.0)	0.94 (24.0)	1.09 (27.7)	2300 (158)
24	1 7/8-12	16	1 5/16-12	-PRB-ST30-US21	1.27 (32.3)	2.13 (54.0)	0.59 (15.0)	0.94 (24.0)	1.23 (31.2)	2300 (158)

Hex Couplings

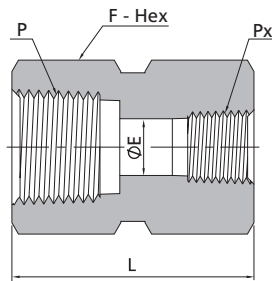

Female NPT Threads								
P-NPT Size	Px-NPT Size	Basic Ordering Number	Dimensions, in. (mm)			Working Pressure psig (bar)		
			L	F	E	316 SS, Steel	Brass	
1/16	1/16	-PCG-NS1	0.78 (19.8)	0.44 (11.1)	0.19 (4.8)	6700 (460)	3300 (227)	
1/8	1/8	-PCG-NS2	0.81 (20.6)	0.56 (14.3)	0.34 (8.6)	6500 (447)	3200 (220)	
1/4	1/8	-PCG-NS4-NS2	1.22 (31.0)	0.75 (19.1)	0.34 (8.6)	6600 (454)	3300 (227)	
1/4	1/4	-PCG-NS4	1.19 (30.2)	0.75 (19.1)	0.45 (11.4)	6600 (454)	3300 (227)	
3/8	1/4	-PCG-NS6-NS4	1.38 (35.1)	0.87 (22.2)	0.45 (11.4)	5300 (365)	2600 (179)	
3/8	3/8	-PCG-NS6	1.31 (33.3)	0.87 (22.2)	0.59 (15.0)	5300 (365)	2600 (179)	
1/2	1/8	-PCG-NS8-NS2	1.56 (39.6)	1.06 (27.0)	0.34 (8.6)	4900 (337)	2400 (165)	
1/2	1/4	-PCG-NS8-NS4	1.75 (44.4)	1.06 (27.0)	0.45 (11.4)	4900 (337)	2400 (165)	
1/2	3/8	-PCG-NS8-NS6	1.78 (45.2)	1.06 (27.0)	0.59 (15.0)	4900 (337)	2400 (165)	
1/2	1/2	-PCG-NS8	1.56 (39.6)	1.06 (27.0)	0.73 (18.5)	4900 (337)	2400 (165)	
3/4	1/4	-PCG-NS12-NS4	1.81 (46.0)	1.31 (33.3)	0.45 (11.4)	4600 (316)	2300 (158)	
3/4	1/2	-PCG-NS12-NS8	2.06 (52.3)	1.31 (33.3)	0.73 (18.5)	4600 (316)	2300 (158)	
3/4	3/4	-PCG-NS12	1.62 (41.1)	1.31 (33.3)	0.94 (23.9)	4600 (316)	2300 (158)	
1	1/2	-PCG-NS16-NS8	2.19 (55.6)	1.63 (41.3)	0.73 (18.5)	4400 (303)	2200 (151)	
1	3/4	-PCG-NS16-NS12	2.25 (57.2)	1.63 (41.3)	0.94 (23.9)	4400 (303)	2200 (151)	
1	1	-PCG-NS16	2.00 (50.8)	1.63 (41.3)	1.17 (29.7)	4400 (303)	2200 (151)	

Female ISO Tapered Threads								
P-RT Size	Px-RT Size	Basic Ordering Number	Dimensions, in. (mm)			Working Pressure psig (bar)		
			L	F	E	316 SS, Steel	Brass	
1/8	1/8	-PCG-RT2	0.81 (20.6)	0.56 (14.3)	0.33 (8.4)	6500 (447)	3200 (220)	
1/4	1/4	-PCG-RT4	1.19 (30.2)	0.75 (19.1)	0.44 (11.2)	6600 (454)	3300 (227)	
3/8	1/4	-PCG-RT6-RT4	1.38 (35.1)	0.87 (22.2)	0.44 (11.2)	5300 (365)	2600 (179)	
3/8	3/8	-PCG-RT6	1.31 (33.3)	0.87 (22.2)	0.58 (14.7)	5300 (365)	2600 (179)	
1/2	1/4	-PCG-RT8-RT4	1.75 (44.4)	1.06 (27.0)	0.44 (11.2)	4900 (337)	2400 (165)	
1/2	3/8	-PCG-RT8-RT6	1.78 (45.2)	1.06 (27.0)	0.58 (14.7)	4900 (337)	2400 (165)	
1/2	1/2	-PCG-RT8	1.56 (39.6)	1.06 (27.0)	0.72 (18.3)	4900 (337)	2400 (165)	

Union Ball Joints

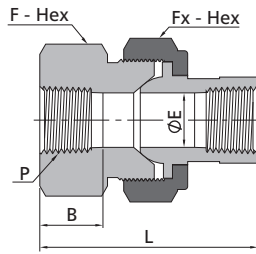

Female NPT Threads							
P-NPT Size	Basic Ordering Number	Dimensions, in. (mm)					Working Pressure psig (bar) 316 SS, Steel
		L	F	Fx	B	E	
1/8	-UBJ-NS2	1.81 (46.0)	0.94 (23.8)	1.13 (28.6)	0.41 (10.4)	0.27 (6.8)	8400 (578)
1/4	-UBJ-NS4	2.34 (59.4)	1.19 (30.2)	1.37 (34.9)	0.59 (15.0)	0.36 (9.1)	6600 (454)
3/8	-UBJ-NS6	2.50 (63.5)	1.31 (33.3)	1.50 (38.1)	0.59 (15.0)	0.52 (13.2)	5300 (365)
1/2	-UBJ-NS8	2.69 (68.3)	1.63 (41.3)	1.75 (44.5)	0.78 (19.8)	0.62 (15.7)	6000 (410)
3/4	-UBJ-NS12	3.12 (79.2)	1.87 (47.6)	2.13 (54.0)	0.81 (20.6)	0.88 (22.4)	4600 (316)
1	-UBJ-NS16	3.56 (90.4)	2.37 (60.3)	2.50 (63.5)	1.00 (25.4)	1.03 (26.2)	6800 (468)

Female ISO Tapered Threads							
P-RT Size	Basic Ordering Number	Dimensions, in. (mm)					Working Pressure psig (bar) 316 SS, Steel
		L	F	Fx	B	E	
1/8	-UBJ-RT2	1.81 (46.0)	0.94 (23.8)	1.13 (28.6)	0.41 (10.4)	0.27 (6.8)	8400 (578)
1/4	-UBJ-RT4	2.34 (59.4)	1.19 (30.2)	1.37 (34.9)	0.59 (15.0)	0.36 (9.1)	6600 (454)
3/8	-UBJ-RT6	2.50 (63.5)	1.31 (33.3)	1.50 (38.1)	0.59 (15.0)	0.52 (13.2)	5300 (365)
1/2	-UBJ-RT8	2.69 (68.3)	1.63 (41.3)	1.75 (44.5)	0.78 (19.8)	0.62 (15.7)	6000 (410)
3/4	-UBJ-RT12	3.12 (79.2)	1.87 (47.6)	2.13 (54.0)	0.81 (20.6)	0.88 (22.4)	4600 (316)
1	-UBJ-RT16	3.56 (90.4)	2.37 (60.3)	2.50 (63.5)	1.00 (25.4)	1.03 (26.2)	6800 (468)

Male Elbows

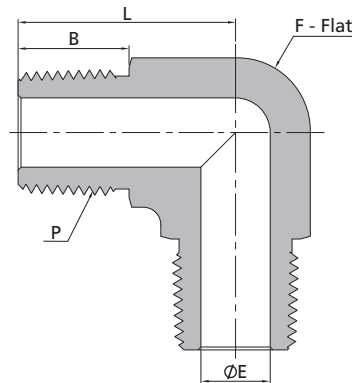

Male NPT Threads							
P-NPT Size	Basic Ordering Number	Dimensions, in. (mm)				Working Pressure psig (bar)	
		L	F	B	E	316 SS, Steel	Brass
1/16	-PME-NS1	0.67 (17.0)	0.37 (9.5)	0.38 (9.7)	0.12 (3.0)	11000 (757)	5500 (378)
1/8	-PME-NS2	0.88 (22.4)	0.44 (11.1)	0.38 (9.7)	0.19 (4.8)	10000 (690)	5000 (344)
1/4	-PME-NS4	1.05 (26.7)	0.50 (12.7)	0.56 (14.2)	0.28 (7.1)	8000 (551)	4000 (275)
3/8	-PME-NS6	1.17 (29.7)	0.69 (17.5)	0.56 (14.2)	0.38 (9.6)	7800 (537)	3900 (268)
1/2	-PME-NS8	1.45 (36.8)	0.81 (20.6)	0.75 (19.1)	0.47 (11.9)	7700 (530)	3800 (261)
3/4	-PME-NS12	1.59 (40.4)	1.06 (27.0)	0.75 (19.1)	0.62 (15.7)	7300 (502)	3600 (248)
1	-PME-NS16	1.97 (50.0)	1.37 (34.9)	0.94 (23.9)	0.88 (22.4)	5300 (365)	2600 (179)

Male ISO Tapered Threads							
P-RT Size	Basic Ordering Number	Dimensions, in. (mm)				Working Pressure psig (bar)	
		L	F	B	E	316 SS, Steel	Brass
1/16	-PME-RT1	0.67 (17.0)	0.37 (9.5)	0.38 (9.7)	0.12 (3.0)	11000 (757)	5500 (378)
1/8	-PME-RT2	0.88 (22.4)	0.44 (11.1)	0.38 (9.7)	0.19 (4.8)	10000 (690)	5000 (344)
1/4	-PME-RT4	1.05 (26.7)	0.50 (12.7)	0.56 (14.2)	0.28 (7.1)	8000 (551)	4000 (275)
3/8	-PME-RT6	1.17 (29.7)	0.69 (17.5)	0.56 (14.2)	0.38 (9.6)	7800 (537)	3900 (268)
1/2	-PME-RT8	1.45 (36.8)	0.81 (20.6)	0.75 (19.1)	0.47 (11.9)	7700 (530)	3800 (261)
3/4	-PME-RT12	1.59 (40.4)	1.06 (27.0)	0.75 (19.1)	0.62 (15.7)	7300 (502)	3600 (248)
1	-PME-RT16	1.97 (50.0)	1.37 (34.9)	0.94 (23.9)	0.88 (22.4)	5300 (365)	2600 (179)

Street Elbows

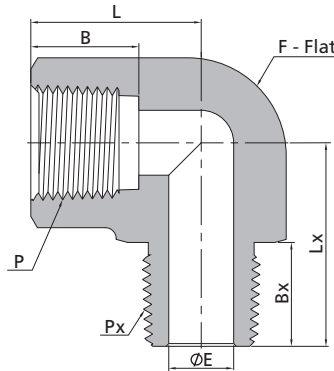

Female NPT Threads				Male NPT Threads						
P-NPT Size	Px-NPT Size	Basic Ordering Number	Dimensions, in. (mm)					Working Pressure psig (bar)		
			L	F	B	E	Lx	Bx	316 SS, Steel	Brass
1/16	1/16	-PSE-NS1	0.86 (21.8)	0.44 (11.1)	0.39 (9.9)	0.12 (3.0)	0.88 (22.4)	0.38 (9.7)	9200 (633)	4600 (316)
1/16	1/8	-PSE-NS1-NS2	0.86 (21.8)	0.44 (11.1)	0.39 (9.9)	0.19 (4.8)	0.88 (22.4)	0.38 (9.7)	9200 (633)	4600 (316)
1/16	1/4	-PSE-NS1-NS4	0.88 (22.4)	0.56 (14.3)	0.39 (9.9)	0.19 (4.8)	1.09 (27.7)	0.56 (14.2)	8000 (551)	4000 (275)
1/16	3/8	-PSE-NS1-NS6	0.88 (22.4)	0.69 (17.5)	0.39 (9.9)	0.19 (4.8)	1.17 (29.7)	0.56 (14.2)	7800 (537)	3900 (268)
1/8	1/16	-PSE-NS2-NS1	1.04 (26.4)	0.50 (12.7)	0.41 (10.4)	0.12 (3.0)	0.87 (22.1)	0.38 (9.7)	6200 (426)	3100 (213)
1/8	1/8	-PSE-NS2	1.04 (26.4)	0.50 (12.7)	0.41 (10.4)	0.19 (4.8)	0.87 (22.1)	0.38 (9.7)	6200 (426)	3100 (213)
1/8	1/4	-PSE-NS2-NS4	0.88 (22.4)	0.56 (14.3)	0.41 (10.4)	0.28 (7.1)	1.09 (27.7)	0.56 (14.2)	6500 (447)	3200 (220)
1/8	3/8	-PSE-NS2-NS6	0.88 (22.4)	0.69 (17.5)	0.41 (10.4)	0.28 (7.1)	1.17 (29.7)	0.56 (14.2)	7800 (537)	3900 (268)
1/8	1/2	-PSE-NS2-NS8	0.95 (24.1)	0.81 (20.6)	0.41 (10.4)	0.28 (7.1)	1.45 (36.8)	0.75 (19.1)	7700 (530)	3800 (261)
1/8	3/4	-PSE-NS2-NS12	1.00 (25.4)	1.06 (27.0)	0.41 (10.4)	0.28 (7.1)	1.59 (40.4)	0.75 (19.1)	7300 (502)	3600 (248)
1/8	1	-PSE-NS2-NS16	1.04 (26.4)	1.37 (34.9)	0.41 (10.4)	0.28 (7.1)	1.97 (50.0)	0.94 (23.9)	5300 (365)	2600 (179)
1/4	1/8	-PSE-NS4-NS2	1.17 (29.7)	0.69 (17.5)	0.59 (15.0)	0.19 (4.8)	1.00 (25.4)	0.38 (9.7)	7200 (496)	3600 (248)
1/4	1/4	-PSE-NS4	1.17 (29.7)	0.69 (17.5)	0.59 (15.0)	0.28 (7.1)	1.17 (29.7)	0.56 (14.2)	7200 (496)	3600 (248)
1/4	3/8	-PSE-NS4-NS6	1.17 (29.7)	0.69 (17.5)	0.59 (15.0)	0.34 (8.6)	1.17 (29.7)	0.56 (14.2)	7200 (496)	3600 (248)
1/4	1/2	-PSE-NS4-NS8	1.00 (25.4)	0.81 (20.6)	0.59 (15.0)	0.34 (8.6)	1.45 (36.8)	0.75 (19.1)	7200 (496)	3600 (248)
1/4	3/4	-PSE-NS4-NS12	1.00 (25.4)	1.06 (27.0)	0.59 (15.0)	0.34 (8.6)	1.59 (40.4)	0.75 (19.1)	7300 (502)	3600 (248)
1/4	1	-PSE-NS4-NS16	1.63 (41.4)	1.37 (34.9)	0.59 (15.0)	0.34 (8.6)	1.97 (50.0)	0.94 (23.9)	5300 (365)	2600 (179)
3/8	1/4	-PSE-NS6-NS4	1.42 (36.1)	0.81 (20.6)	0.59 (15.0)	0.28 (7.1)	1.26 (32.0)	0.56 (14.2)	5600 (385)	2800 (192)
3/8	3/8	-PSE-NS6	1.42 (36.1)	0.81 (20.6)	0.59 (15.0)	0.38 (9.6)	1.26 (32.0)	0.56 (14.2)	5600 (385)	2800 (192)
3/8	1/2	-PSE-NS6-NS8	1.42 (36.1)	0.81 (20.6)	0.59 (15.0)	0.47 (11.9)	1.45 (36.8)	0.75 (19.1)	5600 (385)	2800 (192)
3/8	3/4	-PSE-NS6-NS12	1.23 (31.2)	1.06 (27.0)	0.59 (15.0)	0.47 (11.9)	1.59 (40.4)	0.75 (19.1)	7300 (502)	3600 (248)
3/8	1	-PSE-NS6-NS16	1.63 (41.4)	1.37 (34.9)	0.59 (15.0)	0.47 (11.9)	1.97 (50.0)	0.94 (23.9)	5300 (365)	2600 (179)
1/2	1/4	-PSE-NS8-NS4	1.56 (39.6)	1.00 (25.4)	0.78 (19.8)	0.28 (7.1)	1.38 (35.1)	0.56 (14.2)	5600 (385)	2800 (192)
1/2	3/8	-PSE-NS8-NS6	1.56 (39.6)	1.00 (25.4)	0.78 (19.8)	0.38 (9.6)	1.38 (35.1)	0.56 (14.2)	5600 (385)	2800 (192)
1/2	1/2	-PSE-NS8	1.56 (39.6)	1.00 (25.4)	0.78 (19.8)	0.47 (11.9)	1.56 (39.6)	0.75 (19.1)	5600 (385)	2800 (192)
1/2	3/4	-PSE-NS8-NS12	1.23 (31.2)	1.06 (27.0)	0.78 (19.8)	0.62 (15.7)	1.59 (40.4)	0.75 (19.1)	5600 (385)	2800 (192)
1/2	1	-PSE-NS8-NS16	1.63 (41.4)	1.37 (34.9)	0.78 (19.8)	0.62 (15.7)	1.97 (50.0)	0.94 (23.9)	5300 (365)	2600 (179)
3/4	3/4	-PSE-NS12	1.92 (48.8)	1.25 (31.8)	0.81 (20.6)	0.62 (15.7)	1.67 (42.4)	0.75 (19.1)	5100 (351)	2500 (172)
3/4	1	-PSE-NS12-NS16	1.63 (41.4)	1.37 (34.9)	0.81 (20.6)	0.88 (22.4)	1.97 (50.0)	0.94 (23.9)	5100 (351)	2500 (172)
1	1	-PSE-NS16	1.91 (48.5)	1.69 (42.9)	1.00 (25.4)	0.88 (22.4)	1.94 (49.3)	0.94 (23.9)	5300 (365)	2600 (179)
1 1/4	1 1/4	-PSE-NS20	2.38 (60.5)	2.00 (50.8)	1.00 (25.4)	1.25 (31.8)	2.38 (60.5)	0.94 (23.9)	3100 (213)	1600 (110)

Street Elbows

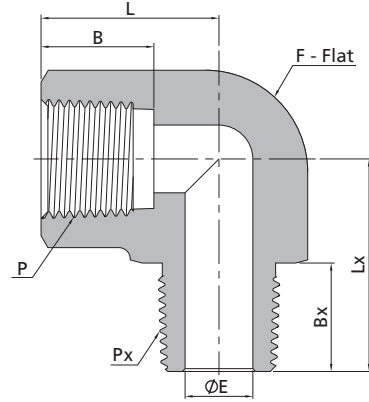

Female ISO Tapered Threads			Male ISO Tapered Threads							
P-RT Size	Px-RT Size	Basic Ordering Number	Dimensions, in. (mm)						Working Pressure psig (bar)	
			L	F	B	E	Lx	Bx	316 SS, Steel	Brass
1/16	1/16	-PSE-RT1	0.86 (21.8)	0.44 (11.1)	0.39 (9.9)	0.12 (3.0)	0.88 (22.4)	0.38 (9.7)	9200 (633)	4600 (316)
1/16	1/8	-PSE-RT1-RT2	0.86 (21.8)	0.44 (11.1)	0.39 (9.9)	0.19 (4.8)	0.88 (22.4)	0.38 (9.7)	9200 (633)	4600 (316)
1/16	1/4	-PSE-RT1-RT4	0.88 (22.4)	0.56 (14.3)	0.39 (9.9)	0.19 (4.8)	1.09 (27.7)	0.56 (14.2)	8000 (551)	4000 (275)
1/16	3/8	-PSE-RT1-RT6	0.88 (22.4)	0.69 (17.5)	0.39 (9.9)	0.19 (4.8)	1.17 (29.7)	0.56 (14.2)	7800 (537)	3900 (268)
1/8	1/16	-PSE-RT2-RT1	1.04 (26.4)	0.50 (12.7)	0.41 (10.4)	0.12 (3.0)	0.87 (22.1)	0.38 (9.7)	6200 (426)	3100 (213)
1/8	1/8	-PSE-RT2	1.04 (26.4)	0.50 (12.7)	0.41 (10.4)	0.19 (4.8)	0.87 (22.1)	0.38 (9.7)	6200 (426)	3100 (213)
1/8	1/4	-PSE-RT2-RT4	0.88 (22.4)	0.56 (14.3)	0.41 (10.4)	0.28 (7.1)	1.09 (27.7)	0.56 (14.2)	6500 (447)	3200 (220)
1/8	3/8	-PSE-RT2-RT6	0.88 (22.4)	0.69 (17.5)	0.41 (10.4)	0.28 (7.1)	1.17 (29.7)	0.56 (14.2)	7800 (537)	3900 (268)
1/8	1/2	-PSE-RT2-RT8	0.95 (24.1)	0.81 (20.6)	0.41 (10.4)	0.28 (7.1)	1.45 (36.8)	0.75 (19.1)	7700 (530)	3800 (261)
1/8	3/4	-PSE-RT2-RT12	1.00 (25.4)	1.06 (27.0)	0.41 (10.4)	0.28 (7.1)	1.59 (40.4)	0.75 (19.1)	7300 (502)	3600 (248)
1/8	1	-PSE-RT2-RT16	1.04 (26.4)	1.37 (34.9)	0.41 (10.4)	0.28 (7.1)	1.97 (50.0)	0.94 (23.9)	5300 (365)	2600 (179)
1/4	1/8	-PSE-RT4-RT2	1.17 (29.7)	0.69 (17.5)	0.59 (15.0)	0.19 (4.8)	1.00 (25.4)	0.38 (9.7)	7200 (496)	3600 (248)
1/4	1/4	-PSE-RT4	1.17 (29.7)	0.69 (17.5)	0.59 (15.0)	0.28 (7.1)	1.17 (29.7)	0.56 (14.2)	7200 (496)	3600 (248)
1/4	3/8	-PSE-RT4-RT6	1.17 (29.7)	0.69 (17.5)	0.59 (15.0)	0.34 (8.6)	1.17 (29.7)	0.56 (14.2)	7200 (496)	3600 (248)
1/4	1/2	-PSE-RT4-RT8	1.00 (25.4)	0.81 (20.6)	0.59 (15.0)	0.34 (8.6)	1.45 (36.8)	0.75 (19.1)	7200 (496)	3600 (248)
1/4	3/4	-PSE-RT4-RT12	1.00 (25.4)	1.06 (27.0)	0.59 (15.0)	0.34 (8.6)	1.59 (40.4)	0.75 (19.1)	7300 (502)	3600 (248)
1/4	1	-PSE-RT4-RT16	1.63 (41.4)	1.37 (34.9)	0.59 (15.0)	0.34 (8.6)	1.97 (50.0)	0.94 (23.9)	5300 (365)	2600 (179)
3/8	1/4	-PSE-RT6-RT4	1.42 (36.1)	0.81 (20.6)	0.59 (15.0)	0.28 (7.1)	1.26 (32.0)	0.56 (14.2)	5600 (385)	2800 (192)
3/8	3/8	-PSE-RT6	1.42 (36.1)	0.81 (20.6)	0.59 (15.0)	0.38 (9.6)	1.26 (32.0)	0.56 (14.2)	5600 (385)	2800 (192)
3/8	1/2	-PSE-RT6-RT8	1.42 (36.1)	0.81 (20.6)	0.59 (15.0)	0.47 (11.9)	1.45 (36.8)	0.75 (19.1)	5600 (385)	2800 (192)
3/8	3/4	-PSE-RT6-RT12	1.23 (31.2)	1.06 (27.0)	0.59 (15.0)	0.47 (11.9)	1.59 (40.4)	0.75 (19.1)	7300 (502)	3600 (248)
3/8	1	-PSE-RT6-RT16	1.63 (41.4)	1.37 (34.9)	0.59 (15.0)	0.47 (11.9)	1.97 (50.0)	0.94 (23.9)	5300 (365)	2600 (179)
1/2	1/4	-PSE-RT8-RT4	1.56 (39.6)	1.00 (25.4)	0.78 (19.8)	0.28 (7.1)	1.38 (35.1)	0.56 (14.2)	5600 (385)	2800 (192)
1/2	3/8	-PSE-RT8-RT6	1.56 (39.6)	1.00 (25.4)	0.78 (19.8)	0.38 (9.6)	1.38 (35.1)	0.56 (14.2)	5600 (385)	2800 (192)
1/2	1/2	-PSE-RT8	1.56 (39.6)	1.00 (25.4)	0.78 (19.8)	0.47 (11.9)	1.56 (39.6)	0.75 (19.1)	5600 (385)	2800 (192)
1/2	3/4	-PSE-RT8-RT12	1.23 (31.2)	1.06 (27.0)	0.78 (19.8)	0.62 (15.7)	1.59 (40.4)	0.75 (19.1)	5600 (385)	2800 (192)
1/2	1	-PSE-RT8-RT16	1.63 (41.4)	1.37 (34.9)	0.78 (19.8)	0.62 (15.7)	1.97 (50.0)	0.94 (23.9)	5300 (365)	2600 (179)
3/4	3/4	-PSE-RT12	1.92 (48.8)	1.25 (31.8)	0.81 (20.6)	0.62 (15.7)	1.67 (42.4)	0.75 (19.1)	5100 (351)	2500 (172)
3/4	1	-PSE-RT12-RT16	1.63 (41.4)	1.37 (34.9)	0.81 (20.6)	0.88 (22.4)	1.97 (50.0)	0.94 (23.9)	5100 (351)	2500 (172)
1	1	-PSE-RT16	1.91 (48.5)	1.69 (42.9)	1.00 (25.4)	0.88 (22.4)	1.94 (49.3)	0.94 (23.9)	5300 (365)	2600 (179)
1 1/4	1 1/4	-PSE-RT20	2.38 (60.5)	2.00 (50.8)	1.00 (25.4)	1.25 (31.8)	2.38 (60.5)	0.94 (23.9)	3100 (213)	1600 (110)

45° Street Elbows

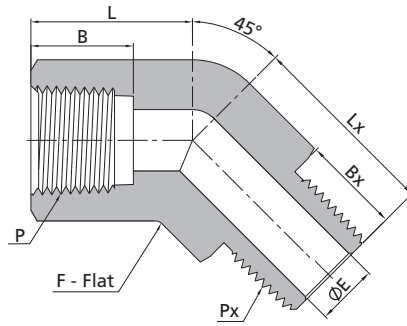

Pipe Fittings
Weld Fittings

Female NPT Threads			Dimensions, in. (mm)							Male NPT Threads	
P-NPT Size	Px-NPT Size	Basic Ordering Number	L	F	B	E	Lx	Bx	Working Pressure psig (bar)		
									316 SS, Steel	Brass	
1/16	1/16	-PSV-NS1	0.66 (16.8)	0.44 (11.1)	0.39 (9.9)	0.12 (3.0)	0.66 (16.8)	0.38 (9.7)	9200 (633)	4600 (316)	
1/16	1/8	-PSV-NS1-NS2	0.66 (16.8)	0.44 (11.1)	0.39 (9.9)	0.19 (4.8)	0.66 (16.8)	0.38 (9.7)	9200 (633)	4600 (316)	
1/16	1/4	-PSV-NS1-NS4	0.66 (16.8)	0.56 (14.3)	0.39 (9.9)	0.19 (4.8)	0.86 (21.8)	0.56 (14.2)	8000 (551)	4000 (275)	
1/16	3/8	-PSV-NS1-NS6	0.88 (22.4)	0.69 (17.5)	0.39 (9.9)	0.19 (4.8)	0.94 (23.8)	0.56 (14.2)	7800 (537)	3900 (268)	
1/8	1/16	-PSV-NS2-NS1	0.80 (20.2)	0.50 (12.7)	0.41 (10.4)	0.12 (3.0)	0.68 (17.2)	0.38 (9.7)	6200 (426)	3100 (213)	
1/8	1/8	-PSV-NS2	0.80 (20.2)	0.50 (12.7)	0.41 (10.4)	0.19 (4.8)	0.68 (17.2)	0.38 (9.7)	6200 (426)	3100 (213)	
1/8	1/4	-PSV-NS2-NS4	0.66 (16.8)	0.56 (14.3)	0.41 (10.4)	0.28 (7.1)	0.86 (21.8)	0.56 (14.2)	6500 (447)	3200 (220)	
1/8	3/8	-PSV-NS2-NS6	0.88 (22.4)	0.69 (17.5)	0.41 (10.4)	0.28 (7.1)	0.94 (23.8)	0.56 (14.2)	7800 (537)	3900 (268)	
1/8	1/2	-PSV-NS2-NS8	0.87 (22.2)	0.81 (20.6)	0.41 (10.4)	0.28 (7.1)	1.14 (29.0)	0.75 (19.1)	7700 (530)	3800 (261)	
1/8	3/4	-PSV-NS2-NS12	1.00 (25.4)	1.06 (27.0)	0.41 (10.4)	0.28 (7.1)	1.20 (30.5)	0.75 (19.1)	7300 (502)	3600 (248)	
1/8	1	-PSV-NS2-NS16	1.04 (26.4)	1.37 (34.9)	0.41 (10.4)	0.28 (7.1)	1.94 (49.3)	0.94 (23.9)	5300 (365)	2600 (179)	
1/4	1/8	-PSV-NS4-NS2	1.00 (25.4)	0.69 (17.5)	0.59 (15.0)	0.19 (4.8)	0.76 (19.3)	0.38 (9.7)	7200 (496)	3600 (248)	
1/4	1/4	-PSV-NS4	1.00 (25.4)	0.69 (17.5)	0.59 (15.0)	0.28 (7.1)	0.76 (19.3)	0.56 (14.2)	7200 (496)	3600 (248)	
1/4	3/8	-PSV-NS4-NS6	1.00 (25.4)	0.69 (17.5)	0.59 (15.0)	0.34 (8.6)	0.94 (23.8)	0.56 (14.2)	7200 (496)	3600 (248)	
1/4	1/2	-PSV-NS4-NS8	0.87 (22.2)	0.81 (20.6)	0.59 (15.0)	0.34 (8.6)	1.14 (29.0)	0.75 (19.1)	7200 (496)	3600 (248)	
1/4	3/4	-PSV-NS4-NS12	1.00 (25.4)	1.06 (27.0)	0.59 (15.0)	0.34 (8.6)	1.20 (30.5)	0.75 (19.1)	7300 (502)	3600 (248)	
1/4	1	-PSV-NS4-NS16	1.26 (32.0)	1.37 (34.9)	0.59 (15.0)	0.34 (8.6)	1.48 (37.6)	0.94 (23.9)	5300 (365)	2600 (179)	
3/8	1/4	-PSV-NS6-NS4	1.06 (27.0)	0.81 (20.6)	0.59 (15.0)	0.28 (7.1)	0.95 (24.2)	0.56 (14.2)	5600 (385)	2800 (192)	
3/8	3/8	-PSV-NS6	1.06 (27.0)	0.81 (20.6)	0.59 (15.0)	0.38 (9.6)	0.95 (24.2)	0.56 (14.2)	5600 (385)	2800 (192)	
3/8	1/2	-PSV-NS6-NS8	1.06 (27.0)	0.81 (20.6)	0.59 (15.0)	0.47 (11.9)	1.14 (29.0)	0.75 (19.1)	5600 (385)	2800 (192)	
3/8	3/4	-PSV-NS6-NS12	1.06 (27.0)	1.06 (27.0)	0.59 (15.0)	0.47 (11.9)	1.20 (30.5)	0.75 (19.1)	7300 (502)	3600 (248)	
3/8	1	-PSV-NS6-NS16	1.26 (32.0)	1.37 (34.9)	0.59 (15.0)	0.47 (11.9)	1.48 (37.6)	0.94 (23.9)	5300 (365)	2600 (179)	
1/2	1/4	-PSV-NS8-NS4	1.26 (32.0)	1.00 (25.4)	0.78 (19.8)	0.28 (7.1)	0.99 (25.2)	0.56 (14.2)	5600 (385)	2800 (192)	
1/2	3/8	-PSV-NS8-NS6	1.26 (32.0)	1.00 (25.4)	0.78 (19.8)	0.38 (9.6)	0.99 (25.2)	0.56 (14.2)	5600 (385)	2800 (192)	
1/2	1/2	-PSV-NS8	1.26 (32.0)	1.00 (25.4)	0.78 (19.8)	0.47 (11.9)	1.26 (32.0)	0.75 (19.1)	5600 (385)	2800 (192)	
1/2	3/4	-PSV-NS8-NS12	1.28 (32.5)	1.06 (27.0)	0.78 (19.8)	0.62 (15.7)	1.20 (30.5)	0.75 (19.1)	5600 (385)	2800 (192)	
1/2	1	-PSV-NS8-NS16	1.48 (37.6)	1.37 (34.9)	0.78 (19.8)	0.62 (15.7)	1.48 (37.6)	0.94 (23.9)	5300 (365)	2600 (179)	
3/4	3/4	-PSV-NS12	1.36 (34.5)	1.25 (31.8)	0.81 (20.6)	0.62 (15.7)	1.36 (34.5)	0.75 (19.1)	5100 (351)	2500 (172)	
3/4	1	-PSV-NS12-NS16	1.48 (37.6)	1.37 (34.9)	0.81 (20.6)	0.88 (22.4)	1.48 (37.6)	0.94 (23.9)	5100 (351)	2500 (172)	
1	1	-PSV-NS16	1.81 (46.0)	1.69 (42.9)	1.00 (25.4)	0.88 (22.4)	1.81 (46.0)	0.94 (23.9)	5300 (365)	2600 (179)	
1 1/4	1 1/4	-PSV-NS20	2.00 (50.8)	2.00 (50.8)	1.00 (25.4)	1.25 (31.8)	2.00 (50.8)	0.94 (23.9)	3100 (213)	1600 (110)	

45° Street Elbows

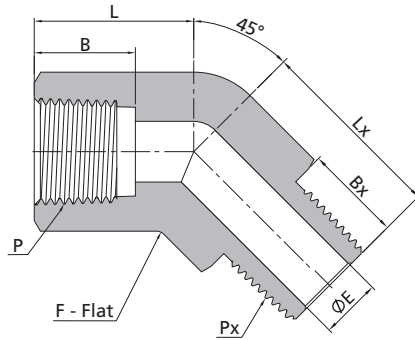

Female ISO Tapered Threads			Male ISO Tapered Threads							
P-RT Size	Px-RT Size	Basic Ordering Number	Dimensions, in. (mm)						Working Pressure psig (bar)	
			L	F	B	E	Lx	Bx	316 SS, Steel	Brass
1/16	1/16	-PSV-RT1	0.66 (16.8)	0.44 (11.1)	0.39 (9.9)	0.12 (3.0)	0.66 (16.8)	0.38 (9.7)	9200 (633)	4600 (316)
1/16	1/8	-PSV-RT1-RT2	0.66 (16.8)	0.44 (11.1)	0.39 (9.9)	0.19 (4.8)	0.66 (16.8)	0.38 (9.7)	9200 (633)	4600 (316)
1/16	1/4	-PSV-RT1-RT4	0.66 (16.8)	0.56 (14.3)	0.39 (9.9)	0.19 (4.8)	0.86 (21.8)	0.56 (14.2)	8000 (551)	4000 (275)
1/16	3/8	-PSV-RT1-RT6	0.88 (22.4)	0.69 (17.5)	0.39 (9.9)	0.19 (4.8)	0.94 (23.8)	0.56 (14.2)	7800 (537)	3900 (268)
1/8	1/16	-PSV-RT2-RT1	0.80 (20.2)	0.50 (12.7)	0.41 (10.4)	0.12 (3.0)	0.68 (17.2)	0.38 (9.7)	6200 (426)	3100 (213)
1/8	1/8	-PSV-RT2	0.80 (20.2)	0.50 (12.7)	0.41 (10.4)	0.19 (4.8)	0.68 (17.2)	0.38 (9.7)	6200 (426)	3100 (213)
1/8	1/4	-PSV-RT2-RT4	0.66 (16.8)	0.56 (14.3)	0.41 (10.4)	0.28 (7.1)	0.86 (21.8)	0.56 (14.2)	6500 (447)	3200 (220)
1/8	3/8	-PSV-RT2-RT6	0.88 (22.4)	0.69 (17.5)	0.41 (10.4)	0.28 (7.1)	0.94 (23.8)	0.56 (14.2)	7800 (537)	3900 (268)
1/8	1/2	-PSV-RT2-RT8	0.87 (22.2)	0.81 (20.6)	0.41 (10.4)	0.28 (7.1)	1.14 (29.0)	0.75 (19.1)	7700 (530)	3800 (261)
1/8	3/4	-PSV-RT2-RT12	1.00 (25.4)	1.06 (27.0)	0.41 (10.4)	0.28 (7.1)	1.20 (30.5)	0.75 (19.1)	7300 (502)	3600 (248)
1/8	1	-PSV-RT2-RT16	1.04 (26.4)	1.37 (34.9)	0.41 (10.4)	0.28 (7.1)	1.94 (49.3)	0.94 (23.9)	5300 (365)	2600 (179)
1/4	1/8	-PSV-RT4-RT2	1.00 (25.4)	0.69 (17.5)	0.59 (15.0)	0.19 (4.8)	0.76 (19.3)	0.38 (9.7)	7200 (496)	3600 (248)
1/4	1/4	-PSV-RT4	1.00 (25.4)	0.69 (17.5)	0.59 (15.0)	0.28 (7.1)	0.76 (19.3)	0.56 (14.2)	7200 (496)	3600 (248)
1/4	3/8	-PSV-RT4-RT6	1.00 (25.4)	0.69 (17.5)	0.59 (15.0)	0.34 (8.6)	0.94 (23.8)	0.56 (14.2)	7200 (496)	3600 (248)
1/4	1/2	-PSV-RT4-RT8	0.87 (22.2)	0.81 (20.6)	0.59 (15.0)	0.34 (8.6)	1.14 (29.0)	0.75 (19.1)	7200 (496)	3600 (248)
1/4	3/4	-PSV-RT4-RT12	1.00 (25.4)	1.06 (27.0)	0.59 (15.0)	0.34 (8.6)	1.20 (30.5)	0.75 (19.1)	7300 (502)	3600 (248)
1/4	1	-PSV-RT4-RT16	1.26 (32.0)	1.37 (34.9)	0.59 (15.0)	0.34 (8.6)	1.48 (37.6)	0.94 (23.9)	5300 (365)	2600 (179)
3/8	1/4	-PSV-RT6-RT4	1.06 (27.0)	0.81 (20.6)	0.59 (15.0)	0.28 (7.1)	0.95 (24.2)	0.56 (14.2)	5600 (385)	2800 (192)
3/8	3/8	-PSV-RT6	1.06 (27.0)	0.81 (20.6)	0.59 (15.0)	0.38 (9.6)	0.95 (24.2)	0.56 (14.2)	5600 (385)	2800 (192)
3/8	1/2	-PSV-RT6-RT8	1.06 (27.0)	0.81 (20.6)	0.59 (15.0)	0.47 (11.9)	1.14 (29.0)	0.75 (19.1)	5600 (385)	2800 (192)
3/8	3/4	-PSV-RT6-RT12	1.06 (27.0)	1.06 (27.0)	0.59 (15.0)	0.47 (11.9)	1.20 (30.5)	0.75 (19.1)	7300 (502)	3600 (248)
3/8	1	-PSV-RT6-RT16	1.26 (32.0)	1.37 (34.9)	0.59 (15.0)	0.47 (11.9)	1.48 (37.6)	0.94 (23.9)	5300 (365)	2600 (179)
1/2	1/4	-PSV-RT8-RT4	1.26 (32.0)	1.00 (25.4)	0.78 (19.8)	0.28 (7.1)	0.99 (25.2)	0.56 (14.2)	5600 (385)	2800 (192)
1/2	3/8	-PSV-RT8-RT6	1.26 (32.0)	1.00 (25.4)	0.78 (19.8)	0.38 (9.6)	0.99 (25.2)	0.56 (14.2)	5600 (385)	2800 (192)
1/2	1/2	-PSV-RT8	1.26 (32.0)	1.00 (25.4)	0.78 (19.8)	0.47 (11.9)	1.26 (32.0)	0.75 (19.1)	5600 (385)	2800 (192)
1/2	3/4	-PSV-RT8-RT12	1.28 (32.5)	1.06 (27.0)	0.78 (19.8)	0.62 (15.7)	1.20 (30.5)	0.75 (19.1)	5600 (385)	2800 (192)
1/2	1	-PSV-RT8-RT16	1.48 (37.6)	1.37 (34.9)	0.78 (19.8)	0.62 (15.7)	1.48 (37.6)	0.94 (23.9)	5300 (365)	2600 (179)
3/4	3/4	-PSV-RT12	1.36 (34.5)	1.25 (31.8)	0.81 (20.6)	0.62 (15.7)	1.36 (34.5)	0.75 (19.1)	5100 (351)	2500 (172)
3/4	1	-PSV-RT12-RT16	1.48 (37.6)	1.37 (34.9)	0.81 (20.6)	0.88 (22.4)	1.48 (37.6)	0.94 (23.9)	5100 (351)	2500 (172)
1	1	-PSV-RT16	1.81 (46.0)	1.69 (42.9)	1.00 (25.4)	0.88 (22.4)	1.81 (46.0)	0.94 (23.9)	5300 (365)	2600 (179)
1 1/4	1 1/4	-PSV-RT20	2.00 (50.8)	2.00 (50.8)	1.00 (25.4)	1.25 (31.8)	2.00 (50.8)	0.94 (23.9)	3100 (213)	1600 (110)

Female Elbows

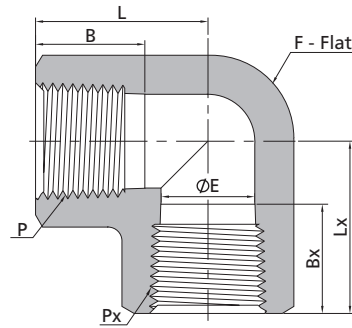

Female NPT Threads

P-NPT Size	Px-NPT Size	Basic Ordering Number	Dimensions, in. (mm)						Working Pressure psig (bar)	
			L	F	B	E	Lx	Bx	316 SS, Steel	Brass
1/16	1/16	-PE-NS1	0.86 (21.8)	0.44 (11.1)	0.39 (9.9)	0.19 (4.8)	0.86 (21.8)	0.39 (9.9)	6700 (460)	3300 (227)
1/8	1/16	-PE-NS2-NS1	1.04 (26.4)	0.50 (12.7)	0.41 (10.4)	0.19 (4.8)	1.04 (26.4)	0.39 (9.9)	6200 (427)	3100 (213)
1/8	1/8	-PE-NS2	1.04 (26.4)	0.50 (12.7)	0.41 (10.4)	0.28 (7.1)	1.04 (26.4)	0.41 (10.4)	6200 (427)	3100 (213)
1/4	1/8	-PE-NS4-NS2	1.17 (29.7)	0.69 (17.5)	0.59 (15.0)	0.28 (7.1)	1.17 (29.7)	0.41 (10.4)	7200 (496)	3600 (248)
1/4	1/4	-PE-NS4	1.17 (29.7)	0.69 (17.5)	0.59 (15.0)	0.41 (10.4)	1.17 (29.7)	0.59 (15.0)	7200 (496)	3600 (248)
3/8	3/8	-PE-NS6	1.42 (36.1)	0.81 (20.6)	0.59 (15.0)	0.50 (12.7)	1.42 (36.1)	0.59 (15.0)	5600 (385)	2800 (192)
1/2	1/2	-PE-NS8	1.56 (39.6)	1.00 (25.4)	0.78 (19.8)	0.67 (17.1)	1.56 (39.6)	0.78 (19.8)	5600 (385)	2800 (192)
3/4	3/4	-PE-NS12	1.92 (48.8)	1.25 (31.8)	0.81 (20.6)	0.88 (22.4)	1.92 (48.8)	0.81 (20.6)	5100 (351)	2500 (172)
1	1	-PE-NS16	1.91 (48.5)	1.69 (42.9)	1.00 (25.4)	1.11 (28.1)	1.91 (48.5)	1.00 (25.4)	6400 (440)	3200 (220)
1 1/4	1 1/4	-PE-NS20	2.35 (59.8)	2.00 (50.8)	1.00 (25.4)	1.09 (27.7)	2.35 (59.8)	1.00 (25.4)	3100 (213)	1600 (110)

Female ISO Tapered Threads

P-RT Size	Px-RT Size	Basic Ordering Number	Dimensions, in. (mm)						Working Pressure psig (bar)	
			L	F	B	E	Lx	Bx	316 SS, Steel	Brass
1/16	1/16	-PE-RT1	0.86 (21.8)	0.44 (11.1)	0.39 (9.9)	0.19 (4.8)	0.86 (21.8)	0.39 (9.9)	6700 (460)	3300 (227)
1/8	1/16	-PE-RT2-RT1	1.04 (26.4)	0.50 (12.7)	0.41 (10.4)	0.19 (4.8)	1.04 (26.4)	0.39 (9.9)	6200 (427)	3100 (213)
1/8	1/8	-PE-RT2	1.04 (26.4)	0.50 (12.7)	0.41 (10.4)	0.28 (7.1)	1.04 (26.4)	0.41 (10.4)	6200 (427)	3100 (213)
1/4	1/8	-PE-RT4-RT2	1.17 (29.7)	0.69 (17.5)	0.59 (15.0)	0.28 (7.1)	1.17 (29.7)	0.41 (10.4)	7200 (496)	3600 (248)
1/4	1/4	-PE-RT4	1.17 (29.7)	0.69 (17.5)	0.59 (15.0)	0.41 (10.4)	1.17 (29.7)	0.59 (15.0)	7200 (496)	3600 (248)
3/8	3/8	-PE-RT6	1.42 (36.1)	0.81 (20.6)	0.59 (15.0)	0.50 (12.7)	1.42 (36.1)	0.59 (15.0)	5600 (385)	2800 (192)
1/2	1/2	-PE-RT8	1.56 (39.6)	1.00 (25.4)	0.78 (19.8)	0.67 (17.1)	1.56 (39.6)	0.78 (19.8)	5600 (385)	2800 (192)
3/4	3/4	-PE-RT12	1.92 (48.8)	1.25 (31.8)	0.81 (20.6)	0.88 (22.4)	1.92 (48.8)	0.81 (20.6)	5100 (351)	2500 (172)
1	1	-PE-RT16	1.91 (48.5)	1.69 (42.9)	1.00 (25.4)	1.11 (28.1)	1.91 (48.5)	1.00 (25.4)	6400 (440)	3200 (220)
1 1/4	1 1/4	-PE-RT20	2.35 (59.8)	2.00 (50.8)	1.00 (25.4)	1.09 (27.7)	2.35 (59.8)	1.00 (25.4)	3100 (213)	1600 (110)

45° Female Elbows

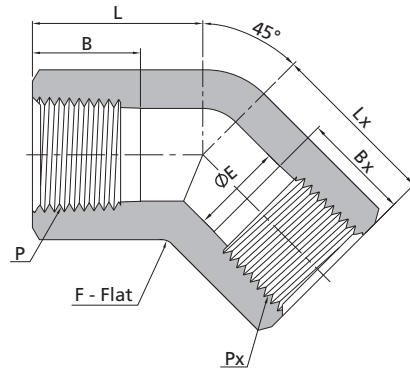

Female NPT Threads											
P-NPT Size	Px-NPT Size	Basic Ordering Number	Dimensions, in. (mm)						Working Pressure psig (bar)		
			L	F	B	E	Lx	Bx	316 SS, Steel	Brass	
1/16	1/16	-PVE-NS1	0.66 (16.8)	0.44 (11.1)	0.39 (9.9)	0.19 (4.8)	0.66 (16.8)	0.39 (9.9)	6700 (460)	3300 (227)	
1/8	1/16	-PVE-NS2-NS1	0.80 (20.2)	0.50 (12.7)	0.41 (10.4)	0.19 (4.8)	0.80 (20.2)	0.39 (9.9)	6200 (427)	3100 (213)	
1/8	1/8	-PVE-NS2	0.80 (20.2)	0.50 (12.7)	0.41 (10.4)	0.28 (7.1)	0.80 (20.2)	0.41 (10.4)	6200 (427)	3100 (213)	
1/4	1/8	-PVE-NS4-NS2	1.00 (25.4)	0.69 (17.5)	0.59 (15.0)	0.28 (7.1)	1.00 (25.4)	0.41 (10.4)	7200 (496)	3600 (248)	
1/4	1/4	-PVE-NS4	1.00 (25.4)	0.69 (17.5)	0.59 (15.0)	0.41 (10.4)	1.00 (25.4)	0.59 (15.0)	7200 (496)	3600 (248)	
3/8	3/8	-PVE-NS6	1.06 (27.0)	0.81 (20.6)	0.59 (15.0)	0.50 (12.7)	1.06 (27.0)	0.59 (15.0)	5600 (385)	2800 (192)	
1/2	1/2	-PVE-NS8	1.26 (32.0)	1.00 (25.4)	0.78 (19.8)	0.67 (17.1)	1.26 (32.0)	0.78 (19.8)	5600 (385)	2800 (192)	
3/4	3/4	-PVE-NS12	1.36 (34.5)	1.25 (31.8)	0.81 (20.6)	0.88 (22.4)	1.36 (34.5)	0.81 (20.6)	5100 (351)	2500 (172)	
1	1	-PVE-NS16	2.46 (62.6)	2.00 (50.8)	1.00 (25.4)	1.11 (28.1)	1.81 (46.0)	1.00 (25.4)	6400 (440)	3200 (220)	
1 1/4	1 1/4	-PVE-NS20	1.70 (43.2)	2.00 (50.8)	1.00 (25.4)	1.09 (27.7)	1.70 (43.2)	1.00 (25.4)	3100 (213)	1600 (110)	

Female ISO Tapered Threads											
P-RT Size	Px-RT Size	Basic Ordering Number	Dimensions, in. (mm)						Working Pressure psig (bar)		
			L	F	B	E	Lx	Bx	316 SS, Steel	Brass	
1/16	1/16	-PVE-RT1	0.66 (16.8)	0.44 (11.1)	0.39 (9.9)	0.19 (4.8)	0.66 (16.8)	0.39 (9.9)	6700 (460)	3300 (227)	
1/8	1/16	-PVE-RT2-RT1	0.80 (20.2)	0.50 (12.7)	0.41 (10.4)	0.19 (4.8)	0.80 (20.2)	0.39 (9.9)	6200 (427)	3100 (213)	
1/8	1/8	-PVE-RT2	0.80 (20.2)	0.50 (12.7)	0.41 (10.4)	0.28 (7.1)	0.80 (20.2)	0.41 (10.4)	6200 (427)	3100 (213)	
1/4	1/8	-PVE-RT4-RT2	1.00 (25.4)	0.69 (17.5)	0.59 (15.0)	0.28 (7.1)	1.00 (25.4)	0.41 (10.4)	7200 (496)	3600 (248)	
1/4	1/4	-PVE-RT4	1.00 (25.4)	0.69 (17.5)	0.59 (15.0)	0.41 (10.4)	1.00 (25.4)	0.59 (15.0)	7200 (496)	3600 (248)	
3/8	3/8	-PVE-RT6	1.06 (27.0)	0.81 (20.6)	0.59 (15.0)	0.50 (12.7)	1.06 (27.0)	0.59 (15.0)	5600 (385)	2800 (192)	
1/2	1/2	-PVE-RT8	1.26 (32.0)	1.00 (25.4)	0.78 (19.8)	0.67 (17.1)	1.26 (32.0)	0.78 (19.8)	5600 (385)	2800 (192)	
3/4	3/4	-PVE-RT12	1.36 (34.5)	1.25 (31.8)	0.81 (20.6)	0.88 (22.4)	1.36 (34.5)	0.81 (20.6)	5100 (351)	2500 (172)	
1	1	-PVE-RT16	2.46 (62.6)	2.00 (50.8)	1.00 (25.4)	1.11 (28.1)	1.81 (46.0)	1.00 (25.4)	6400 (440)	3200 (220)	
1 1/4	1 1/4	-PVE-RT20	1.70 (43.2)	2.00 (50.8)	1.00 (25.4)	1.09 (27.7)	1.70 (43.2)	1.00 (25.4)	3100 (213)	1600 (110)	

Male Tees

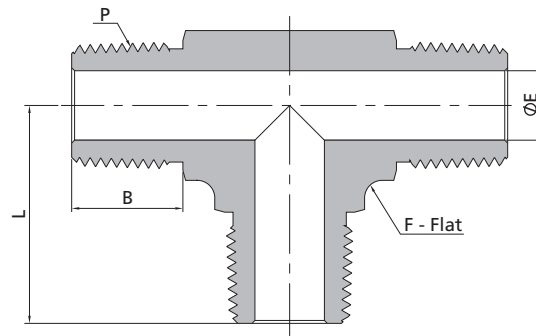

Male NPT Threads							
P-NPT Size	Basic Ordering Number	Dimensions, in. (mm)				Working Pressure psig (bar)	
		L	F	B	E	316 SS, Steel	Brass
1/16	-PMT-NS1	0.67 (17.0)	0.37 (9.5)	0.38 (9.7)	0.12 (3.0)	11000 (757)	5500 (378)
1/8	-PMT-NS2	0.88 (22.4)	0.44 (11.1)	0.38 (9.7)	0.19 (4.8)	10000 (690)	5000 (344)
1/4	-PMT-NS4	1.05 (26.7)	0.50 (12.7)	0.56 (14.2)	0.28 (7.1)	8000 (551)	4000 (275)
3/8	-PMT-NS6	1.17 (29.7)	0.69 (17.5)	0.56 (14.2)	0.38 (9.6)	7800 (537)	3900 (268)
1/2	-PMT-NS8	1.45 (36.8)	0.81 (20.6)	0.75 (19.1)	0.47 (11.9)	7700 (530)	3800 (261)
3/4	-PMT-NS12	1.67 (42.4)	1.06 (27.0)	0.75 (19.1)	0.62 (15.7)	7300 (502)	3600 (248)
1	-PMT-NS16	1.94 (49.3)	1.37 (34.9)	0.94 (23.9)	0.88 (22.4)	5300 (365)	2600 (179)

Male ISO Tapered Threads							
P-RT Size	Basic Ordering Number	Dimensions, in. (mm)				Working Pressure psig (bar)	
		L	F	B	E	316 SS, Steel	Brass
1/16	-PMT-RT1	0.67 (17.0)	0.37 (9.5)	0.38 (9.7)	0.12 (3.0)	11000 (757)	5500 (378)
1/8	-PMT-RT2	0.88 (22.4)	0.44 (11.1)	0.38 (9.7)	0.19 (4.8)	10000 (690)	5000 (344)
1/4	-PMT-RT4	1.05 (26.7)	0.50 (12.7)	0.56 (14.2)	0.28 (7.1)	8000 (551)	4000 (275)
3/8	-PMT-RT6	1.17 (29.7)	0.69 (17.5)	0.56 (14.2)	0.38 (9.6)	7800 (537)	3900 (268)
1/2	-PMT-RT8	1.45 (36.8)	0.81 (20.6)	0.75 (19.1)	0.47 (11.9)	7700 (530)	3800 (261)
3/4	-PMT-RT12	1.67 (42.4)	1.06 (27.0)	0.75 (19.1)	0.62 (15.7)	7300 (502)	3600 (248)
1	-PMT-RT16	1.94 (49.3)	1.37 (34.9)	0.94 (23.9)	0.88 (22.4)	5300 (365)	2600 (179)

Female Branch Tees

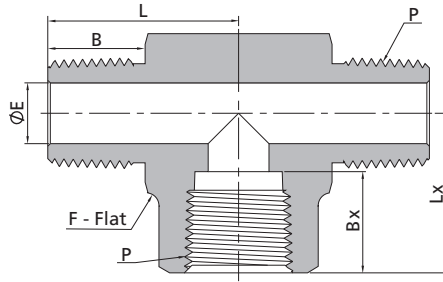

NPT Threads		Dimensions, in. (mm)						Working Pressure psig (bar)	
P-NPT Size	Basic Ordering Number	L	F	E	B	Lx	Bx	316 SS, Steel	Brass
		1/16	-PTB-NS1	0.72 (18.3)	0.44 (11.1)	0.12 (3.0)	0.38 (9.7)	0.86 (21.8)	0.39 (9.9)
1/8	-PTB-NS2	0.87 (22.1)	0.50 (12.7)	0.19 (4.8)	0.38 (9.7)	1.04 (26.4)	0.41 (10.4)	6200 (427)	3100 (213)
1/4	-PTB-NS4	1.17 (29.7)	0.69 (17.5)	0.28 (7.1)	0.56 (14.2)	1.17 (29.7)	0.59 (15.0)	7200 (496)	3600 (248)
3/8	-PTB-NS6	1.26 (32.0)	0.81 (20.6)	0.38 (9.6)	0.56 (14.2)	1.42 (36.1)	0.59 (15.0)	5600 (385)	2800 (192)
1/2	-PTB-NS8	1.56 (39.6)	1.00 (25.4)	0.47 (11.9)	0.75 (19.1)	1.56 (39.6)	0.78 (19.8)	5600 (385)	2800 (192)
3/4	-PTB-NS12	1.67 (42.4)	1.25 (31.8)	0.62 (15.7)	0.75 (19.1)	1.92 (48.8)	0.81 (20.6)	5100 (351)	2500 (172)
1	-PTB-NS16	2.05 (52.0)	1.69 (42.9)	0.88 (22.4)	0.94 (23.9)	1.91 (48.5)	1.00 (25.4)	5300 (365)	2600 (179)

ISO Tapered Threads		Dimensions, in. (mm)						Working Pressure psig (bar)	
P-RT Size	Basic Ordering Number	L	F	E	B	Lx	Bx	316 SS, Steel	Brass
		1/16	-PTB-RT1	0.72 (18.3)	0.44 (11.1)	0.12 (3.0)	0.38 (9.7)	0.86 (21.8)	0.39 (9.9)
1/8	-PTB-RT2	0.87 (22.1)	0.50 (12.7)	0.19 (4.8)	0.38 (9.7)	1.04 (26.4)	0.41 (10.4)	6200 (427)	3100 (213)
1/4	-PTB-RT4	1.17 (29.7)	0.69 (17.5)	0.28 (7.1)	0.56 (14.2)	1.17 (29.7)	0.59 (15.0)	7200 (496)	3600 (248)
3/8	-PTB-RT6	1.26 (32.0)	0.81 (20.6)	0.38 (9.6)	0.56 (14.2)	1.42 (36.1)	0.59 (15.0)	5600 (385)	2800 (192)
1/2	-PTB-RT8	1.56 (39.6)	1.00 (25.4)	0.47 (11.9)	0.75 (19.1)	1.56 (39.6)	0.78 (19.8)	5600 (385)	2800 (192)
3/4	-PTB-RT12	1.67 (42.4)	1.25 (31.8)	0.62 (15.7)	0.75 (19.1)	1.92 (48.8)	0.81 (20.6)	5100 (351)	2500 (172)
1	-PTB-RT16	2.05 (52.0)	1.69 (42.9)	0.88 (22.4)	0.94 (23.9)	1.91 (48.5)	1.00 (25.4)	5300 (365)	2600 (179)

Female Run Tees

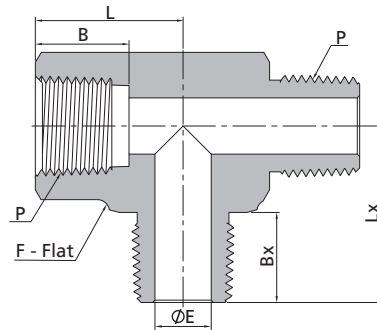

NPT Threads		Dimensions, in. (mm)						Working Pressure psig (bar)	
P-NPT Size	Basic Ordering Number	L	F	E	B	Lx	Bx	316 SS, Steel	Brass
		1/16	-PTR-NS1	0.86 (21.8)	0.44 (11.1)	0.12 (3.0)	0.39 (9.9)	0.72 (18.3)	0.38 (9.7)
1/8	-PTR-NS2	1.04 (26.4)	0.50 (12.7)	0.19 (4.8)	0.41 (10.4)	0.87 (22.1)	0.38 (9.7)	6200 (427)	3100 (213)
1/4	-PTR-NS4	1.17 (29.7)	0.69 (17.5)	0.28 (7.1)	0.59 (15.0)	1.17 (29.7)	0.56 (14.2)	7200 (496)	3600 (248)
3/8	-PTR-NS6	1.42 (36.1)	0.81 (20.6)	0.38 (9.6)	0.59 (15.0)	1.26 (32.0)	0.56 (14.2)	5600 (385)	2800 (192)
1/2	-PTR-NS8	1.56 (39.6)	1.00 (25.4)	0.47 (11.9)	0.78 (19.8)	1.56 (39.6)	0.75 (19.1)	5600 (385)	2800 (192)
3/4	-PTR-NS12	1.92 (48.8)	1.25 (31.8)	0.62 (15.7)	0.81 (20.6)	1.67 (42.4)	0.75 (19.1)	5100 (351)	2500 (172)
1	-PTR-NS16	1.91 (48.5)	1.69 (42.9)	0.88 (22.4)	1.00 (25.4)	1.94 (49.3)	0.94 (23.9)	5300 (365)	2600 (179)

ISO Tapered Threads									
P-RT Size	Basic Ordering Number	Dimensions, in. (mm)						Working Pressure psig (bar)	
		L	F	E	B	Lx	Bx	316 SS, Steel	Brass
1/16	-PTR-RT1	0.86 (21.8)	0.44 (11.1)	0.12 (3.0)	0.39 (9.9)	0.72 (18.3)	0.38 (9.7)	9200 (633)	4600 (316)
1/8	-PTR-RT2	1.04 (26.4)	0.50 (12.7)	0.19 (4.8)	0.41 (10.4)	0.87 (22.1)	0.38 (9.7)	6200 (427)	3100 (213)
1/4	-PTR-RT4	1.17 (29.7)	0.69 (17.5)	0.28 (7.1)	0.59 (15.0)	1.17 (29.7)	0.56 (14.2)	7200 (496)	3600 (248)
3/8	-PTR-RT6	1.42 (36.1)	0.81 (20.6)	0.38 (9.6)	0.59 (15.0)	1.26 (32.0)	0.56 (14.2)	5600 (385)	2800 (192)
1/2	-PTR-RT8	1.56 (39.6)	1.00 (25.4)	0.47 (11.9)	0.78 (19.8)	1.56 (39.6)	0.75 (19.1)	5600 (385)	2800 (192)
3/4	-PTR-RT12	1.92 (48.8)	1.25 (31.8)	0.62 (15.7)	0.81 (20.6)	1.67 (42.4)	0.75 (19.1)	5100 (351)	2500 (172)
1	-PTR-RT16	1.91 (48.5)	1.69 (42.9)	0.88 (22.4)	1.00 (25.4)	1.94 (49.3)	0.94 (23.9)	5300 (365)	2600 (179)

Male Street Tees

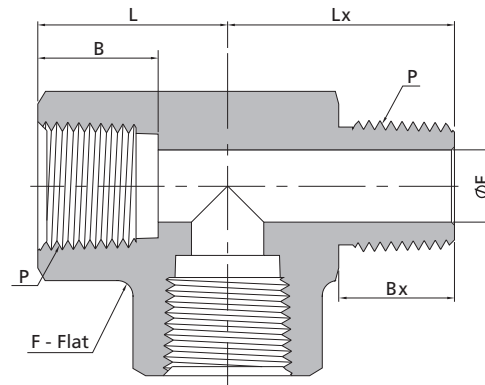

NPT Threads									
P-NPT Size	Basic Ordering Number	Dimensions, in. (mm)						Working Pressure psig (bar)	
		L	F	E	B	Lx	Bx	316 SS, Steel	Brass
1/16	-PST-NS1	0.86 (21.8)	0.44 (11.1)	0.12 (3.0)	0.39 (9.9)	0.72 (18.3)	0.38 (9.7)	9200 (633)	4600 (316)
1/8	-PST-NS2	1.04 (26.4)	0.50 (12.7)	0.19 (4.8)	0.41 (10.4)	0.87 (22.1)	0.38 (9.7)	6200 (427)	3100 (213)
1/4	-PST-NS4	1.17 (29.7)	0.69 (17.5)	0.28 (7.1)	0.59 (15.0)	1.17 (29.7)	0.56 (14.2)	7200 (496)	3600 (248)
3/8	-PST-NS6	1.42 (36.1)	0.81 (20.6)	0.38 (9.6)	0.59 (15.0)	1.26 (32.0)	0.56 (14.2)	5600 (385)	2800 (192)
1/2	-PST-NS8	1.56 (39.6)	1.00 (25.4)	0.47 (11.9)	0.78 (19.8)	1.56 (39.6)	0.75 (19.1)	5600 (385)	2800 (192)
3/4	-PST-NS12	1.92 (48.8)	1.25 (31.8)	0.62 (15.7)	0.81 (20.6)	1.67 (42.4)	0.75 (19.1)	5100 (351)	2500 (172)
1	-PST-NS16	1.91 (48.5)	1.69 (42.9)	0.88 (22.4)	1.00 (25.4)	1.94 (49.3)	0.94 (23.9)	5300 (365)	2600 (179)

ISO Tapered Threads									
P-RT Size	Basic Ordering Number	Dimensions, in. (mm)						Working Pressure psig (bar)	
		L	F	E	B	Lx	Bx	316 SS, Steel	Brass
1/16	-PST-RT1	0.86 (21.8)	0.44 (11.1)	0.12 (3.0)	0.39 (9.9)	0.72 (18.3)	0.38 (9.7)	9200 (633)	4600 (316)
1/8	-PST-RT2	1.04 (26.4)	0.50 (12.7)	0.19 (4.8)	0.41 (10.4)	0.87 (22.1)	0.38 (9.7)	6200 (427)	3100 (213)
1/4	-PST-RT4	1.17 (29.7)	0.69 (17.5)	0.28 (7.1)	0.59 (15.0)	1.17 (29.7)	0.56 (14.2)	7200 (496)	3600 (248)
3/8	-PST-RT6	1.42 (36.1)	0.81 (20.6)	0.38 (9.6)	0.59 (15.0)	1.26 (32.0)	0.56 (14.2)	5600 (385)	2800 (192)
1/2	-PST-RT8	1.56 (39.6)	1.00 (25.4)	0.47 (11.9)	0.78 (19.8)	1.56 (39.6)	0.75 (19.1)	5600 (385)	2800 (192)
3/4	-PST-RT12	1.92 (48.8)	1.25 (31.8)	0.62 (15.7)	0.81 (20.6)	1.67 (42.4)	0.75 (19.1)	5100 (351)	2500 (172)
1	-PST-RT16	1.91 (48.5)	1.69 (42.9)	0.88 (22.4)	1.00 (25.4)	1.94 (49.3)	0.94 (23.9)	5300 (365)	2600 (179)

Male Branch Tees

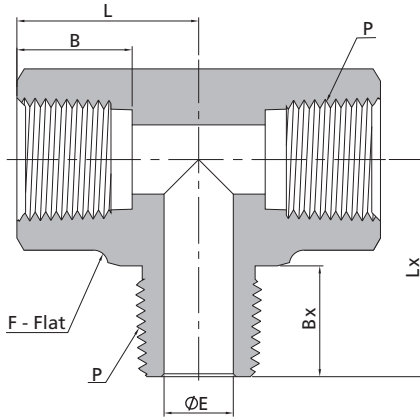

NPT Threads									
P-NPT Size	Basic Ordering Number	Dimensions, in. (mm)						Working Pressure psig (bar)	
		L	F	E	B	Lx	Bx	316 SS, Steel	Brass
1/16	-PBT-NS1	0.86 (21.8)	0.44 (11.1)	0.12 (3.0)	0.39 (9.9)	0.72 (18.3)	0.38 (9.7)	9200 (633)	4600 (316)
1/8	-PBT-NS2	1.04 (26.4)	0.50 (12.7)	0.19 (4.8)	0.41 (10.4)	0.87 (22.1)	0.38 (9.7)	6200 (427)	3100 (213)
1/4	-PBT-NS4	1.17 (29.7)	0.69 (17.5)	0.28 (7.1)	0.59 (15.0)	1.17 (29.7)	0.56 (14.2)	7200 (496)	3600 (248)
3/8	-PBT-NS6	1.42 (36.1)	0.81 (20.6)	0.38 (9.6)	0.59 (15.0)	1.26 (32.0)	0.56 (14.2)	5600 (385)	2800 (192)
1/2	-PBT-NS8	1.56 (39.6)	1.00 (25.4)	0.47 (11.9)	0.78 (19.8)	1.56 (39.6)	0.75 (19.1)	5600 (385)	2800 (192)
3/4	-PBT-NS12	1.92 (48.8)	1.25 (31.8)	0.62 (15.7)	0.81 (20.6)	1.67 (42.4)	0.75 (19.1)	5100 (351)	2500 (172)
1	-PBT-NS16	1.91 (48.5)	1.69 (42.9)	0.88 (22.4)	1.00 (25.4)	1.94 (49.3)	0.94 (23.9)	5300 (365)	2600 (179)

ISO Tapered Threads									
P-RT Size	Basic Ordering Number	Dimensions, in. (mm)						Working Pressure psig (bar)	
		L	F	E	B	Lx	Bx	316 SS, Steel	Brass
1/16	-PBT-RT1	0.86 (21.8)	0.44 (11.1)	0.12 (3.0)	0.39 (9.9)	0.72 (18.3)	0.38 (9.7)	9200 (633)	4600 (316)
1/8	-PBT-RT2	1.04 (26.4)	0.50 (12.7)	0.19 (4.8)	0.41 (10.4)	0.87 (22.1)	0.38 (9.7)	6200 (427)	3100 (213)
1/4	-PBT-RT4	1.17 (29.7)	0.69 (17.5)	0.28 (7.1)	0.59 (15.0)	1.17 (29.7)	0.56 (14.2)	7200 (496)	3600 (248)
3/8	-PBT-RT6	1.42 (36.1)	0.81 (20.6)	0.38 (9.6)	0.59 (15.0)	1.26 (32.0)	0.56 (14.2)	5600 (385)	2800 (192)
1/2	-PBT-RT8	1.56 (39.6)	1.00 (25.4)	0.47 (11.9)	0.78 (19.8)	1.56 (39.6)	0.75 (19.1)	5600 (385)	2800 (192)
3/4	-PBT-RT12	1.92 (48.8)	1.25 (31.8)	0.62 (15.7)	0.81 (20.6)	1.67 (42.4)	0.75 (19.1)	5100 (351)	2500 (172)
1	-PBT-RT16	1.91 (48.5)	1.69 (42.9)	0.88 (22.4)	1.00 (25.4)	1.94 (49.3)	0.94 (23.9)	5300 (365)	2600 (179)

Female Tees

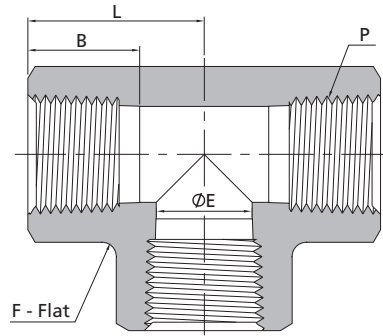

Female NPT Threads							
P-NPT Size	Basic Ordering Number	Dimensions, in. (mm)				Working Pressure psig (bar)	
		L	F	E	B	316 SS, Steel	Brass
1/16	-PT-NS1	0.86 (21.8)	0.44 (11.1)	0.19 (4.8)	0.39 (9.9)	6700 (460)	3300 (227)
1/8	-PT-NS2	1.04 (26.4)	0.50 (12.7)	0.34 (8.6)	0.41 (10.4)	6200 (427)	3100 (213)
1/4	-PT-NS4	1.17 (29.7)	0.69 (17.5)	0.45 (11.4)	0.59 (15.0)	7200 (496)	3600 (248)
3/8	-PT-NS6	1.42 (36.1)	0.81 (20.6)	0.59 (15.0)	0.59 (15.0)	5600 (385)	2800 (192)
1/2	-PT-NS8	1.56 (39.6)	1.00 (25.4)	0.73 (18.5)	0.78 (19.8)	5600 (385)	2800 (192)
3/4	-PT-NS12	1.92 (48.8)	1.25 (31.8)	0.94 (23.9)	0.81 (20.6)	5100 (351)	2500 (172)
1	-PT-NS16	1.91 (48.5)	1.69 (42.9)	1.17 (29.7)	1.00 (25.4)	6400 (440)	3200 (220)
1 1/4	-PT-NS20	2.35 (59.8)	2.00 (50.8)	1.46 (37.2)	1.00 (25.4)	3100 (213)	1600 (110)
1 1/2	-PT-NS24	2.56 (65.0)	2.50 (63.5)	1.70 (43.3)	1.09 (27.7)	5100 (351)	2500 (172)

Female ISO Tapered Threads							
P-RT Size	Basic Ordering Number	Dimensions, in. (mm)				Working Pressure psig (bar)	
		L	F	E	B	316 SS, Steel	Brass
1/16	-PT-RT1	0.86 (21.8)	0.44 (11.1)	0.19 (4.8)	0.39 (9.9)	6700 (460)	3300 (227)
1/8	-PT-RT2	1.04 (26.4)	0.50 (12.7)	0.34 (8.6)	0.41 (10.4)	6200 (427)	3100 (213)
1/4	-PT-RT4	1.17 (29.7)	0.69 (17.5)	0.44 (11.2)	0.59 (15.0)	7200 (496)	3600 (248)
3/8	-PT-RT6	1.42 (36.1)	0.81 (20.6)	0.58 (14.7)	0.59 (15.0)	5600 (385)	2800 (192)
1/2	-PT-RT8	1.56 (39.6)	1.00 (25.4)	0.72 (18.3)	0.78 (19.8)	5600 (385)	2800 (192)
3/4	-PT-RT12	1.92 (48.8)	1.25 (31.8)	0.94 (23.9)	0.81 (20.6)	5100 (351)	2500 (172)
1	-PT-RT16	1.91 (48.5)	1.69 (42.9)	1.17 (29.7)	1.00 (25.4)	6400 (440)	3200 (220)
1 1/4	-PT-RT20	2.35 (59.8)	2.00 (50.8)	1.46 (37.2)	1.00 (25.4)	3100 (213)	1600 (110)
1 1/2	-PT-RT24	2.56 (65.0)	2.50 (63.5)	1.70 (43.3)	1.09 (27.7)	5100 (351)	2500 (172)

Female Crosses

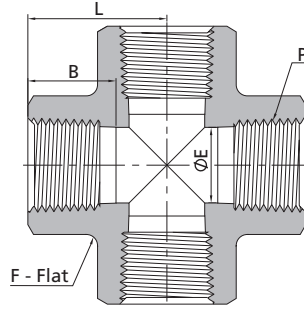

Female NPT Threads							
P-NPT Size	Basic Ordering Number	Dimensions, in. (mm)				Working Pressure psig (bar)	
		L	F	E	B	316 SS, Steel	Brass
1/16	-PCR-NS1	0.86 (21.8)	0.44 (11.1)	0.19 (4.8)	0.39 (9.9)	6700 (460)	3300 (227)
1/8	-PCR-NS2	1.04 (26.4)	0.50 (12.7)	0.34 (8.6)	0.41 (10.4)	6200 (427)	3100 (213)
1/4	-PCR-NS4	1.17 (29.7)	0.69 (17.5)	0.45 (11.4)	0.59 (15.0)	7200 (496)	3600 (248)
3/8	-PCR-NS6	1.42 (36.1)	0.81 (20.6)	0.59 (15.0)	0.59 (15.0)	5600 (385)	2800 (192)
1/2	-PCR-NS8	1.56 (39.6)	1.00 (25.4)	0.73 (18.5)	0.78 (19.8)	5600 (385)	2800 (192)
3/4	-PCR-NS12	1.92 (48.8)	1.25 (31.8)	0.94 (23.9)	0.81 (20.6)	5100 (351)	2500 (172)
1	-PCR-NS16	1.91 (48.5)	1.69 (42.9)	1.17 (29.7)	1.00 (25.4)	6400 (440)	3200 (220)

Female ISO Tapered Threads							
P-RT Size	Basic Ordering Number	Dimensions, in. (mm)				Working Pressure psig (bar)	
		L	F	E	B	316 SS, Steel	Brass
1/16	-PCR-RT1	0.86 (21.8)	0.44 (11.1)	0.19 (4.8)	0.39 (9.9)	6700 (460)	3300 (227)
1/8	-PCR-RT2	1.04 (26.4)	0.50 (12.7)	0.34 (8.6)	0.41 (10.4)	6200 (427)	3100 (213)
1/4	-PCR-RT4	1.17 (29.7)	0.69 (17.5)	0.45 (11.4)	0.59 (15.0)	7200 (496)	3600 (248)
3/8	-PCR-RT6	1.42 (36.1)	0.81 (20.6)	0.59 (15.0)	0.59 (15.0)	5600 (385)	2800 (192)
1/2	-PCR-RT8	1.56 (39.6)	1.00 (25.4)	0.73 (18.5)	0.78 (19.8)	5600 (385)	2800 (192)
3/4	-PCR-RT12	1.92 (48.8)	1.25 (31.8)	0.94 (23.9)	0.81 (20.6)	5100 (351)	2500 (172)
1	-PCR-RT16	1.91 (48.5)	1.69 (42.9)	1.17 (29.7)	1.00 (25.4)	6400 (440)	3200 (220)

Pipe to Pipe Unions

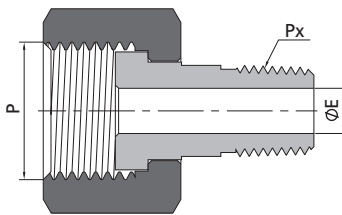

Metric Threads			NPT Threads	
P-Metric Thread Size	Px-NPT Size	Basic Ordering Number	Dimensions, in. (mm)	Working Pressure psig (bar)
			E	316 SS, Steel
M20 x 1.5	1/8	-PUP-MS20-NS2	0.19 (4.8)	4500 (310)
M20 x 1.5	1/4	-PUP-MS20-NS4	0.28 (7.1)	4500 (310)

Metric Threads			ISO Tapered Threads	
P-Metric Thread Size	Px-RT Size	Basic Ordering Number	Dimensions, in. (mm)	Working Pressure psig (bar)
			E	316 SS, Steel
M20 x 1.5	1/8	-PUP-MS20-RT2	0.19 (4.8)	4500 (310)
M20 x 1.5	1/4	-PUP-MS20-RT4	0.28 (7.1)	4500 (310)

ISO Parallel Threads			NPT Threads	
P-ISO Pipe Size	Px-NPT Size	Basic Ordering Number	Dimensions, in. (mm)	Working Pressure psig (bar) 316 SS, Steel
			E	
1/2	1/8	-PUP-RG8-NS2	0.19 (4.8)	4900 (337)
1/2	1/4	-PUP-RG8-NS4	0.28 (7.1)	4900 (337)

Hand Tight Adapter Fittings

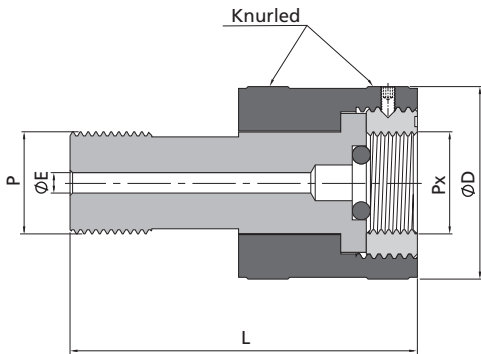

Metric Threads						
P-Metric Thread Size	Px-Metric Thread Size	Basic Ordering Number	Dimensions, mm (in.)			Working Pressure psig (bar) 316 SS, Steel
			L	D	E	
M14 x 1.5	M14 x 1.5	-HF-MS14	58.0 (2.28)	27.0 (1.06)	3.2 (0.13)	6100 (425)
M14 x 1.5	M20 x 1.5	-HF-MS14-MS20	58.0 (2.28)	37.5 (1.48)	3.2 (0.13)	5700 (393)
M20 x 1.5	M14 x 1.5	-HF-MS20-MS14	68.0 (2.68)	32.0 (1.26)	4.0 (0.16)	6100 (425)
M20 x 1.5	M20 x 1.5	-HF-MS20	68.0 (2.68)	37.5 (1.48)	4.0 (0.16)	5700 (393)
M20 x 1.5	M22 x 1.5	-HF-MS20-MS22	68.0 (2.68)	37.5 (1.48)	4.0 (0.16)	4000 (275)

Metric Threads			ISO Parallel Threads			
P-Metric Thread Size	Px-ISO Thread Size	Basic Ordering Number	Dimensions, mm (in.)			Working Pressure psig (bar) 316 SS, Steel
			L	D	E	
M20 x 1.5	1/4	-HF-MS20-RG4	68.0 (2.68)	32.0 (1.26)	3.2 (0.13)	6500 (447)
M20 x 1.5	3/8	-HF-MS20-RG6	68.0 (2.68)	32.0 (1.26)	3.6 (0.14)	4300 (297)
M20 x 1.5	1/2	-HF-MS20-RG8	68.0 (2.68)	37.5 (1.48)	4.0 (0.16)	4800 (334)

ISO Parallel Threads						
P-ISO Thread Size	Px-ISO Thread Size	Basic Ordering Number	Dimensions, mm (in.)			Working Pressure psig (bar) 316 SS, Steel
			L	D	E	
1/2	1/4	-HF-BP8-RG4	68.0 (2.68)	32.0 (1.26)	3.2 (0.13)	6500 (447)
1/2	3/8	-HF-BP8-RG6	68.0 (2.68)	32.0 (1.26)	3.6 (0.14)	4300 (297)
1/2	1/2	-HF-BP8-RG8	68.0 (2.68)	37.5 (1.48)	4.0 (0.16)	4800 (334)

Pipe Plugs

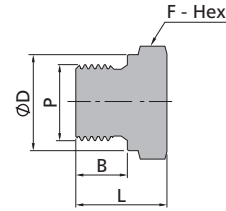
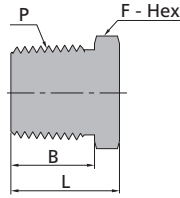

Male NPT Threads					
P-NPT Size	Basic Ordering Number	Dimensions, in. (mm)			
		L	F	B	
1/16	-PP-NS1	0.56 (14.2)	0.31 (7.9)	0.38 (9.7)	
1/8	-PP-NS2	0.56 (14.2)	0.44 (11.1)	0.38 (9.7)	
1/4	-PP-NS4	0.75 (19.1)	0.56 (14.3)	0.56 (14.2)	
3/8	-PP-NS6	0.78 (19.8)	0.69 (17.5)	0.56 (14.2)	
1/2	-PP-NS8	0.97 (24.6)	0.87 (22.2)	0.75 (19.1)	
3/4	-PP-NS12	1.21 (30.7)	1.06 (27.0)	0.75 (19.1)	
1	-PP-NS16	1.50 (38.1)	1.37 (34.9)	0.94 (23.9)	
1 1/4	-PP-NS20	1.51 (38.4)	1.75 (44.5)	0.94 (23.9)	
1 1/2	-PP-NS24	1.72 (43.7)	2.00 (50.8)	1.03 (26.2)	
2	-PP-NS32	2.00 (50.8)	2.50 (63.5)	1.06 (26.9)	

Male ISO Parallel Threads					
P-RS Size	Basic Ordering Number	Dimensions, in. (mm)			
		L	F	B	D
1/8	-PP-RS2	0.55 (14.0)	0.56 (14.3)	0.28 (7.1)	0.54 (13.7)
1/4	-PP-RS4	0.78 (19.8)	0.75 (19.1)	0.44 (11.2)	0.71 (18.0)
3/8	-PP-RS6	0.78 (19.8)	0.87 (22.2)	0.44 (11.2)	0.86 (21.8)
1/2	-PP-RS8	0.99 (25.1)	1.06 (27.0)	0.55 (14.0)	1.02 (25.9)
3/4	-PP-RS12	1.13 (28.7)	1.31 (33.3)	0.62 (15.7)	1.26 (32.0)
1	-PP-RS16	1.21 (30.7)	1.63 (41.3)	0.71 (18.0)	1.54 (39.1)

Male ISO Tapered Threads					
P-RT Size	Basic Ordering Number	Dimensions, in. (mm)			
		L	F	B	
1/16	-PP-RT1	0.56 (14.2)	0.31 (7.9)	0.38 (9.7)	
1/8	-PP-RT2	0.56 (14.2)	0.44 (11.1)	0.38 (9.7)	
1/4	-PP-RT4	0.75 (19.1)	0.56 (14.3)	0.56 (14.2)	
3/8	-PP-RT6	0.78 (19.8)	0.69 (17.5)	0.56 (14.2)	
1/2	-PP-RT8	0.97 (24.6)	0.87 (22.2)	0.75 (19.1)	
3/4	-PP-RT12	1.21 (30.7)	1.06 (27.0)	0.75 (19.1)	
1	-PP-RT16	1.50 (38.1)	1.37 (34.9)	0.94 (23.9)	
1 1/4	-PP-RT20	1.51 (38.4)	1.75 (44.5)	0.94 (23.9)	
1 1/2	-PP-RT24	1.72 (43.7)	2.00 (50.8)	1.03 (26.2)	
2	-PP-RT32	2.00 (50.8)	2.50 (63.5)	1.06 (26.9)	

Male Metric Threads					
P-Metric Size	Basic Ordering Number	Dimensions, mm (in.)			
		L	F	B	D
M14 x 1.5	-PP-MRS14	21.0 (0.83)	20.6 (0.81)	12.0 (0.47)	18.8 (0.74)
M16 x 1.5	-PP-MRS16	23.0 (0.91)	22.2 (0.87)	12.0 (0.47)	20.8 (0.82)
M18 x 1.5	-PP-MRS18	25.0 (0.98)	23.8 (0.94)	12.0 (0.47)	22.8 (0.90)
M20 x 1.5	-PP-MRS20	26.5 (1.04)	25.4 (1.00)	14.0 (0.55)	24.8 (0.98)
M22 x 1.5	-PP-MRS22	28.8 (1.13)	28.6 (1.13)	14.0 (0.55)	26.8 (1.06)
M24 x 1.5	-PP-MRS24	29.0 (1.14)	35.0 (1.38)	14.0 (0.55)	28.8 (1.13)
M27 x 2	-PP-MRS27	30.0 (1.18)	36.5 (1.44)	16.0 (0.63)	31.8 (1.25)

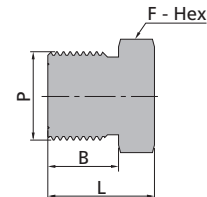
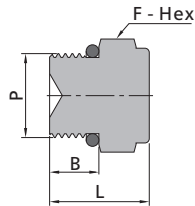

Male SAE/MS Straight Threads (ST)					
P-SAE Nominal Thread Size	P-SAE/MS Specification Number	Basic Ordering Number	Dimensions, in. (mm)		
			L	F	B
4	7/16-20	-PP-ST7	0.76 (19.3)	0.56 (14.3)	0.36 (9.1)
6	9/16-18	-PP-ST9	0.82 (20.8)	0.69 (17.5)	0.39 (9.9)
8	3/4-16	-PP-ST12	0.89 (22.6)	0.87 (22.2)	0.44 (11.2)
12	1 1/16-12	-PP-ST17	1.12 (28.4)	1.25 (31.8)	0.59 (15.0)
16	1 5/16-12	-PP-ST21	1.18 (30.0)	1.50 (38.1)	0.59 (15.0)

Male Metric Threads				
P-Metric Size	Basic Ordering Number	Dimensions, mm (in.)		
		L	F	B
M14 x 1.5	-PP-MS14	18.0 (0.71)	16.0 (0.63)	13.0 (0.51)
M16 x 1.5	-PP-MS16	20.0 (0.79)	18.0 (0.71)	14.0 (0.55)
M18 x 1.5	-PP-MS18	22.0 (0.87)	19.0 (0.75)	15.0 (0.59)
M20 x 1.5	-PP-MS20	24.0 (0.94)	22.0 (0.87)	16.0 (0.63)
M22 x 1.5	-PP-MS22	26.0 (1.02)	24.0 (0.94)	17.0 (0.67)
M24 x 1.5	-PP-MS24	26.0 (1.02)	27.0 (1.06)	17.0 (0.67)
M27 x 2	-PP-MS27	27.0 (1.06)	30.0 (1.18)	18.0 (0.71)
M30 x 2	-PP-MS30	32.0 (1.26)	32.0 (1.26)	20.0 (0.79)

Dimensions are for reference only, subject to change.

Hollow Hex Plugs

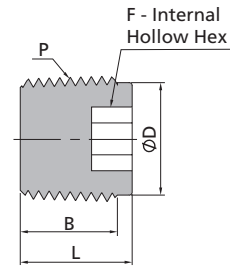
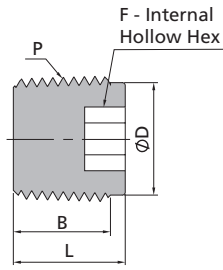

Pipe Fittings
Weld Fittings

Male NPT Threads

P-NPT Size	Basic Ordering Number	Dimensions, in. (mm)			
		L	F	B	D
1/16	-PI-NS1	0.30 (7.6)	0.16 (4.0)	0.29 (7.4)	0.29 (7.4)
1/8	-PI-NS2	0.41 (10.4)	0.19 (4.8)	0.29 (7.4)	0.37 (9.4)
1/4	-PI-NS4	0.61 (15.5)	0.25 (6.4)	0.49 (12.4)	0.48 (12.1)
3/8	-PI-NS6	0.59 (15.0)	0.31 (7.9)	0.47 (11.9)	0.62 (15.7)
1/2	-PI-NS8	0.76 (19.3)	0.37 (9.5)	0.64 (16.2)	0.76 (19.3)
3/4	-PI-NS12	0.78 (19.8)	0.56 (14.3)	0.66 (16.7)	1.01 (25.7)
1	-PI-NS16	0.82 (20.8)	0.63 (15.9)	0.70 (17.7)	1.25 (31.8)

Male ISO Tapered Threads

P-RT Size	Basic Ordering Number	Dimensions, in. (mm)			
		L	F	B	D
1/16	-PI-RT1	0.30 (7.6)	0.16 (4.0)	0.29 (7.4)	0.29 (7.4)
1/8	-PI-RT2	0.41 (10.4)	0.19 (4.8)	0.29 (7.4)	0.37 (9.4)
1/4	-PI-RT4	0.61 (15.5)	0.25 (6.4)	0.49 (12.4)	0.48 (12.1)
3/8	-PI-RT6	0.61 (15.5)	0.31 (7.9)	0.49 (12.4)	0.62 (15.7)
1/2	-PI-RT8	0.76 (19.3)	0.37 (9.5)	0.64 (16.2)	0.76 (19.3)
3/4	-PI-RT12	0.78 (19.8)	0.56 (14.3)	0.66 (16.7)	1.01 (25.7)
1	-PI-RT16	0.82 (20.8)	0.63 (15.9)	0.70 (17.7)	1.25 (31.8)

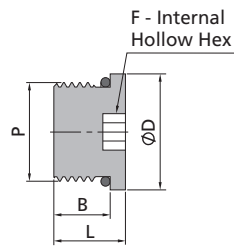

Male SAE/MS Straight Threads (ST)

P-SAE Nominal Size	P-SAE/MS Thread Specification	Basic Ordering Number	Dimensions, in. (mm)			
			L	F	B	D
4	7/16-20	-PI-ST7	0.45 (11.4)	0.19 (4.8)	0.36 (9.1)	0.56 (14.2)
6	9/16-18	-PI-ST9	0.48 (12.2)	0.25 (6.4)	0.39 (9.9)	0.69 (17.5)
8	3/4-16	-PI-ST12	0.56 (14.2)	0.31 (7.9)	0.44 (11.2)	0.88 (22.4)
12	1 1/16-12	-PI-ST17	0.75 (19.1)	0.56 (14.3)	0.59 (15.0)	1.25 (31.8)
16	1 5/16-12	-PI-ST21	0.75 (19.1)	0.63 (15.9)	0.59 (15.0)	1.50 (38.1)

Pipe Caps

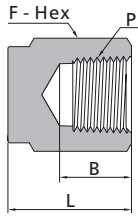

Female NPT Threads						
P-NPT Size	Basic Ordering Number	Dimensions, in. (mm)			Working Pressure psig (bar)	
		L	F	B	316 SS, Steel	Brass
1/16	-PC-NS1	0.50 (12.7)	0.44 (11.1)	0.39 (9.9)	6700 (460)	3300 (227)
1/8	-PC-NS2	0.75 (19.1)	0.56 (14.3)	0.41 (10.4)	6500 (447)	3200 (220)
1/4	-PC-NS4	0.91 (23.1)	0.75 (19.1)	0.59 (15.0)	6600 (454)	3300 (277)
3/8	-PC-NS6	1.03 (26.2)	0.87 (22.2)	0.59 (15.0)	5300 (365)	2600 (179)
1/2	-PC-NS8	1.34 (34.0)	1.06 (27.0)	0.78 (19.8)	4900 (337)	2400 (165)
3/4	-PC-NS12	1.44 (36.6)	1.31 (33.3)	0.81 (20.6)	4600 (316)	2300 (158)
1	-PC-NS16	1.62 (41.1)	1.63 (41.3)	1.00 (25.4)	4400 (303)	2200 (151)

Female ISO Tapered Threads						
P-RT Size	Basic Ordering Number	Dimensions, in. (mm)			Working Pressure psig (bar)	
		L	F	B	316 SS, Steel	Brass
1/16	-PC-RT1	0.50 (12.7)	0.44 (11.1)	0.39 (9.9)	6700 (460)	3300 (227)
1/8	-PC-RT2	0.75 (19.1)	0.56 (14.3)	0.41 (10.4)	6500 (447)	3200 (220)
1/4	-PC-RT4	0.91 (23.1)	0.75 (19.1)	0.59 (15.0)	6600 (454)	3300 (277)
3/8	-PC-RT6	1.03 (26.2)	0.87 (22.2)	0.59 (15.0)	5300 (365)	2600 (179)
1/2	-PC-RT8	1.34 (34.0)	1.06 (27.0)	0.78 (19.8)	4900 (337)	2400 (165)
3/4	-PC-RT12	1.44 (36.6)	1.31 (33.3)	0.81 (20.6)	4600 (316)	2300 (158)
1	-PC-RT16	1.62 (41.1)	1.63 (41.3)	1.00 (25.4)	4400 (303)	2200 (151)

Ordering Number Description

SS - PSE - NS6 - NS4 - □ - □ - □ - S - □

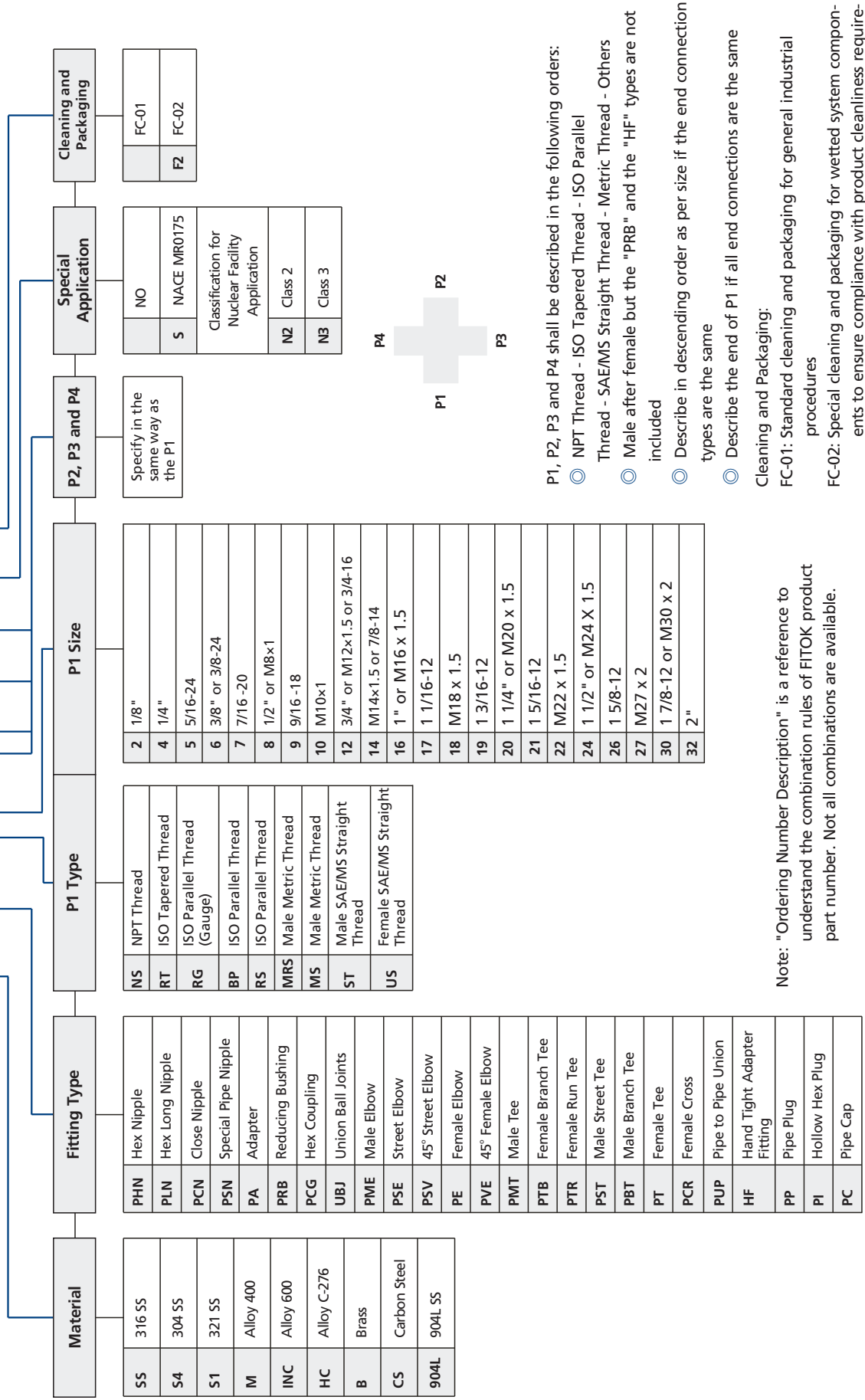

Material	
SS	316 SS
S4	304 SS
S1	321 SS
M	Alloy 400
INC	Alloy 600
HC	Alloy C-276
B	Brass
CS	Carbon Steel
904L	904L SS

Fitting Type	
PHN	Hex Nipple
PLN	Hex Long Nipple
PCN	Close Nipple
PSN	Special Pipe Nipple
PA	Adapter
PRB	Reducing Bushing
PCG	Hex Coupling
UBJ	Union Ball Joints
PME	Male Elbow
PSE	Street Elbow
PSV	45° Street Elbow
PE	Female Elbow
PVE	45° Female Elbow
PMT	Male Tee
PTB	Female Branch Tee
PTR	Female Run Tee
PST	Male Street Tee
PBT	Male Branch Tee
PT	Female Tee
PCR	Female Cross
PUP	Pipe to Pipe Union
HF	Hand Tight Adapter Fitting
PP	Pipe Plug
PI	Hollow Hex Plug
PC	Pipe Cap

P1 Type	
NS	NPT Thread
RT	ISO Tapered Thread
RG	ISO Parallel Thread (Gauge)
BP	ISO Parallel Thread
RS	ISO Parallel Thread
MRS	Male Metric Thread
MS	Male Metric Thread
ST	Male SAE/MS Straight Thread
US	Female SAE/MS Straight Thread

P1 Size	
2	1/8"
4	1/4"
5	5/16-24
6	3/8" or 3/8-24
7	7/16-20
8	1/2" or M8x1
9	9/16-18
10	M10x1
12	3/4" or M12x1.5 or 3/4-16
14	M14x1.5 or 7/8-14
16	1" or M16 x 1.5
17	1 1/16-12
18	M18 x 1.5
19	1 3/16-12
20	1 1/4" or M20 x 1.5
21	1 5/16-12
22	M22 x 1.5
24	1 1/2" or M24 X 1.5
26	1 5/8-12
27	M27 x 2
30	1 7/8-12 or M30 x 2
32	2"

Special Application	
NO	
S	NACE MR0175
Classification for Nuclear Facility Application	
N2	Class 2
N3	Class 3

Cleaning and Packaging	
FC-01	
F2	FC-02

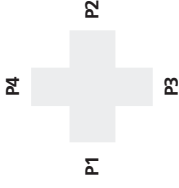

- P1, P2, P3 and P4 shall be described in the following orders:
- NPT Thread - ISO Tapered Thread - ISO Parallel Thread - SAE/MS Straight Thread - Metric Thread - Others
 - Male after female but the "PRB" and the "HF" types are not included
 - Describe in descending order as per size if the end connection types are the same
 - Describe the end of P1 if all end connections are the same
- Cleaning and Packaging:
- FC-01: Standard cleaning and packaging for general industrial procedures
 - FC-02: Special cleaning and packaging for wetted system components to ensure compliance with product cleanliness requirements as stated in ASTM G93 Level C

Note: "Ordering Number Description" is a reference to understand the combination rules of FITOK product part number. Not all combinations are available.

info@fitok.com
www.fitok.com

FK-IC-GF-02-EN-230412