

Needle Valves

NB, ND, NDH, NF, NFH, NG, NGH, NR, NRG,
NT, NU, NUH and NY Series

Needle Valves
Metering Valves



Contents

Screwed Bonnet Needle Valves

NB Series



B-76

Nonrotating-stem Needle Valves

ND Series and NDH Series



B-81

Forged Body Needle Valves

NF Series and NFH Series



B-85

Integral Bonnet Needle Valves

NG Series and NGH Series



B-91

Rising Plug Valves

NR Series and NRG Series



B-98

Toggle Valves

NT Series



B-102

Union Bonnet Needle Valves

NU Series and NUH Series



B-106

Outside Screw and Yoke (OS&Y) Needle Valves

NY Series



B-112

Notes:

- ⦿ Packing adjustment may be required during the service life of the valve
- ⦿ For better quality maintenance, FITOK instrumentation needle valves should be kept in half open position in warehouse

Screwed Bonnet Needle Valves

NB Series: Working pressure up to 6000 psig



Features

- ⦿ Cold drawn bar as body
- ⦿ Two-piece stem design: Upper stem threads cold rolled and lower stem hardened for high strength and smooth operation
- ⦿ Upper stem thread lubricant isolated from system media
- ⦿ Linear instead of rotary motion of the rising, non-rotating stem minimizes packing abrasion and reduces the friction between the seat and the tip
- ⦿ Safety back seating seal in fully open position
- ⦿ Panel mounting available
- ⦿ Steady and durable fastening of the handle by double lock-pins
- ⦿ Handles of different colors available
- ⦿ Every valve leak tested with Nitrogen or compressed air at the maximum allowable working pressure
- ⦿ Working pressure up to:
 - Stainless steel: 6000 psig (414 bar)
 - Alloy C-276: 6000 psig (414 bar)
 - Alloy 400: 5000 psig (345 bar)
 - Titanium: 3500 psig (241 bar)
 - Brass: 3000 psig (207 bar)
- ⦿ Working temperature:
 - PTFE: -65°F to 450°F (-54°C to 232°C)
 - PEEK: -65°F to 500°F (-54°C to 260°C)
 - Graphite: -65°F to 1200°F (-54°C to 649°C)

Pressure vs. Temperature

NB Series

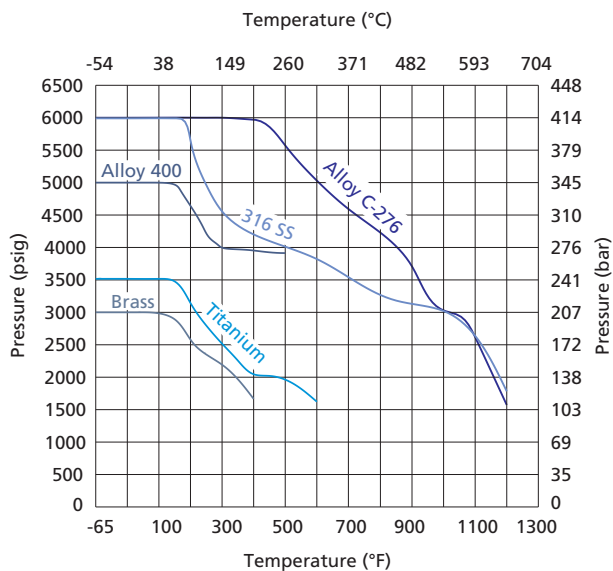

1. Graphs are based on graphite packing.
2. Temperature rating is limited to 200°F (93°C) max. with PCTFE stem tip (soft tip).
3. Contact FITOK Group or our authorized distributors for curve graph of other materials.

Flow Data at 100°F (38°C)

Regulating Stem Tip

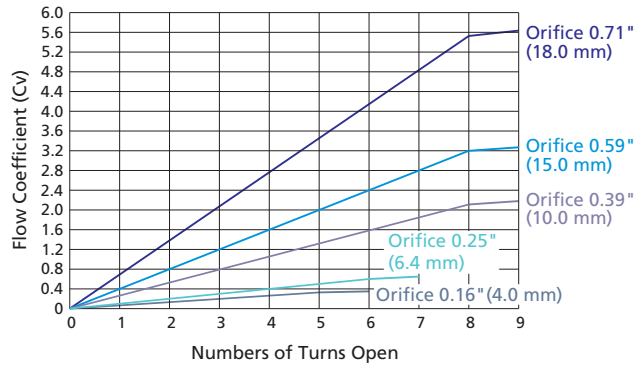

Standard Materials of Construction

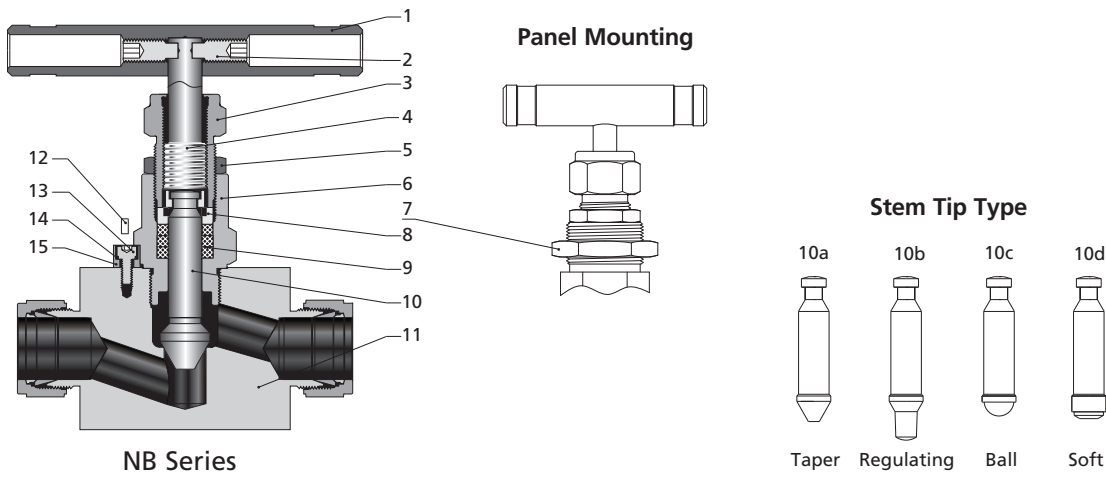

Item	Component	Valve Body Material				
		316 SS	Alloy 400	Titanium	Alloy C-276	Brass
		Material Grade/ASTM Specification				
1	Handle	Anodized aluminum or stainless steel or black knob				
2	Set Screw	Galvanized carbon steel				
3	Packing Bolt	304 SS/A479			Brass C36000/B16	
4	Upper Stem	316 SS/A479				
5	Lock Nut	Stainless steel				
6	Bonnet	316 SS/A479	Alloy 400/B164	Titanium Gr 4/B348	Alloy C-276/B574	Brass C36000/B16

Needle Valves
Metering Valves

B-78 Needle Valves

Item	Component	Valve Body Material				
		316 SS	Alloy 400	Titanium	Alloy C-276	Brass
Material Grade/ASTM Specification						
7	Panel Nut	Stainless steel				Brass C36000/B16
8	Gland	316 SS/A479				
9	Packing	PTFE or PEEK or graphite				
10a 10b 10c	Lower Stem	Hardened 316 SS/A479	Alloy 400/B164	Titanium Gr 4/B348	Alloy C-276/B574	Hardened 316 SS/A479
10d	Stem	316 SS/A479	Alloy 400/B164	Titanium Gr 4/B348	Alloy C-276/B574	316 SS/A479
	Stem Tip	PTFE or PCTFE				
11	Body	316 SS/A479	Alloy 400/B164	Titanium Gr 4/B348	Alloy C-276/B574	Brass C36000/B16
	Seat	Same as body				
12	Lock Pin	Stainless steel				
13	Screw	Stainless steel				
14	Spring Washer	Stainless steel				
15	Bush	Stainless steel				
	Lubricant	Molybdenum disulfide-based				

- Item 12 is applied in valves with orifice of 4.0 and 6.0mm. For valves with orifice of 10.0, 15.0 and 18.0mm, item 13, 14 and 15 are used instead of item 12.
- Contact FITOK Group or our authorized distributors for other materials.

Dimensions

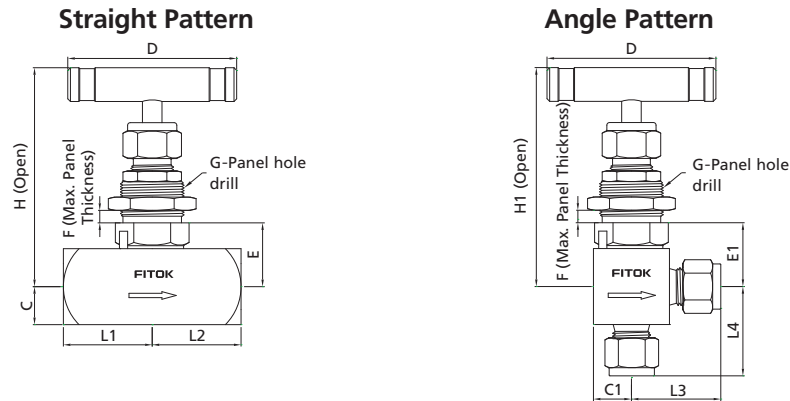

- ⊙ NB Series Needle Valves are standard without panel mounting. To order needle valves with panel mounting as illustrated, add -Y to the ordering number. Example: NBSS-FNS2-7-Y

Dimensions of NB Series

Basic Ordering Number	Connection Type and Size	Connection Pressure at 100°F (38°C) psig (bar)	Orifice in.(mm)	Cv	Dimensions, in.(mm)													
					L1	L2	L3	L4	C	C1	D	E	E1	F	G	H	H1	
NB□□-FNS2-7	1/8 Female NPT	6000 (414)	0.16 (4.0)	0.35	1.00 (25.4)	1.00 (25.4)	1.00 (25.4)	0.56 (14.3)	0.50 (12.7)	0.50 (12.7)	2.17 (55)	0.84 (21.4)	0.82 (20.9)	0.25 (6.4)	0.77 (19.6)	2.86 (72.7)	2.86 (72.7)	
NB□□-FNS4-7	1/4 Female NPT				1.06 (26.9)	1.06 (26.9)												
NB□□-NS4-7	1/4 Male NPT				1.03 (26.2)	1.03 (26.2)	1.06 (26.9)	1.06 (26.9)										
NB□□-NS6-7	3/8 Male NPT				1.19 (30.2)	1.19 (30.2)												
NB□□-FL4-7	1/4" FITOK																	
NB□□-ML6-7	6 mm FITOK																	
NB□□-ML8-7	8 mm FITOK																	
NB□□-FNS4-8	1/4 Female NPT		0.25 (6.4)	0.85	0.85	1.12 (28.6)	1.12 (28.6)	1.12 (28.6)	0.63 (15.9)	0.56 (14.3)	0.56 (14.3)	2.50 (63.5)	0.89 (22.5)	0.89 (22.5)	0.38 (9.7)	0.96 (24.4)	3.50 (88.9)	3.50 (88.9)
NB□□-FNS6-8	3/8 Female NPT																	
NB□□-NS6-8	3/8 Male NPT					1.12 (28.6)	1.12 (28.6)	1.12 (28.6)	0.63 (15.9)									
NB□□-FL6-8	3/8" FITOK					1.41 (35.8)	1.41 (35.8)	1.32 (33.6)	1.32 (33.6)									
NB□□-FL8-8	1/2" FITOK					1.52 (38.6)	1.52 (38.6)	1.42 (36.1)	1.42 (36.1)									

FITOK

Dimensions of NB Series

Basic Ordering Number	Connection Type and Size	Connection Pressure at 100°F (38°C) psig (bar)	Orifice in.(mm)	Cv	Dimensions, in.(mm)																
					Inlet/Outlet	316 SS	L1	L2	L3	L4	C	C1	D	E	E1	F	G	H	H1		
NB□□-ML10-8	10 mm FITOK	6000 (414)	0.25 (6.4)	0.85	1.42 (36.1)	1.42 (36.1)	1.33 (33.8)	1.33 (33.8)													
NB□□-ML12-8	12 mm FITOK				1.52 (38.6)	1.52 (38.6)															
NB□□-ML14-8	14 mm FITOK				1.56 (39.7)	1.56 (39.7)	1.42 (36.1)	1.42 (36.1)													
NB□□-TS6-8-G	3/8" Tube Socket Weld																				
NB□□-TS8-8-G	1/2" Tube Socket Weld																				
NB□□-MTS12-8-G	12 mm Tube Socket Weld							1.13 (28.6)	1.13 (28.6)	1.13 (28.6)	1.13 (28.6)										
NB□□-MTS14-8-G	14 mm Tube Socket Weld											0.56 (14.3)	0.56 (14.3)	2.50 (63.5)	0.89 (22.5)	0.89 (22.5)	0.38 (9.7)	0.96 (24.4)	3.50 (88.9)	3.50 (88.9)	
NB□□-MTS16-8-G	16 mm Tube Socket Weld																				
NB□□-MTB14-8-G	14x2.5 mm Tube Butt Weld							1.50 (38.1)	1.50 (38.1)	1.50 (38.1)	1.50 (38.1)										
NB□□-MTB16-8-G	16x2.8 mm Tube Butt Weld																				
NB□□-UMB14-8	14x2.5 mm Rotatable Tube Butt Weld							2.92 (74.1)	2.92 (74.1)												
NB□□-UMB16-8	16x2.8 mm Rotatable Tube Butt Weld																				
NB□□-MS20-8	M20 x 1.5 Male Metric							1.50 (38.1)	1.50 (38.1)												
NB□□-MS22-8	M22 x 1.5 Male Metric																				
NB□□-FNS8-9	1/2 Female NPT																				
NB□□-FNS12-9	3/4 Female NPT				1.75 (44.5)	1.75 (44.5)	1.63 (41.3)	1.50 (38.1)													
NB□□-NS12-9	3/4 Male NPT						1.50 (38.1)														
NB□□-FL12-9	3/4" FITOK	5800 (400)																			
NB□□-ML14-9	14 mm FITOK	6000 (414)																			
NB□□-ML16-9	16 mm FITOK	5800 (400)	0.39 (10.0)	2.18	1.97 (50.0)	1.97 (50.0)	1.61 (41.0)	1.61 (41.0)	0.88 (22.2)	0.77 (19.5)	3.50 (88.9)	1.38 (34.9)	1.25 (31.75)	0.38 (9.7)	1.08 (27.5)	4.11 (104.5)	4.11 (104.5)				
NB□□-ML18-9	18 mm FITOK	5370 (370)																			
NB□□-MTS14-9-G	14 mm Tube Socket Weld	6000 (414)			1.75 (44.5)	1.75 (44.5)															
NB□□-MTS16-9-G	16 mm Tube Socket Weld																				
NB□□-TS12-9-G	3/4" Tube Socket Weld																				
NB□□-UMB14-9	14x2.5 mm Rotatable Tube Butt Weld					2.98 (75.7)	2.98 (75.7)														
NB□□-MS27-9	M27 x 2 Male Metric					1.56 (39.7)	1.56 (39.7)														
NB□□-FNS12-6	3/4 Female NPT						1.75 (44.5)	1.14 (29.0)													
NB□□-TS16-6-G	1" Tube Socket Weld		0.59 (15.0)	3.27																	
NB□□-MTS25-6-G	25 mm Tube Socket Weld				1.75 (44.5)	1.75 (44.5)	1.75 (44.5)	1.75 (44.5)	1.14 (29.0)	0.88 (22.2)	5.00 (127)	1.70 (43.2)	1.43 (36.4)	0.38 (9.7)	1.28 (32.5)	5.00 (127)	4.72 (120)				
NB□□-MTS28-6-G	28 mm Tube Socket Weld	5000 (345)																			
NB□□-PS12-6-G	3/4 Pipe Socket Weld	5770 (398)																			
NB□□-FNS16-0	1 Female NPT	4350 (300)																			
NB□□-MTS25-0-G	25 mm Tube Socket Weld	6000 (414)	0.71 (18.0)	5.65																	
NB□□-TS16-0-G	1" Tube Socket Weld					1.97 (50.0)	1.97 (50.0)			1.24 (31.5)		5.00 (127)									
NB□□-MTS28-0-G	28 mm Tube Socket Weld																		5.25 (133.3)		
NB□□-PS12-0-G	3/4 Pipe Socket Weld																				
NB□□-PS16-0-G	1 Pipe Socket Weld				3700 (255)																

1. Connection type of "FITOK" means FITOK double ferrule tube fittings. When the connection type of valves is FITOK double ferrule tube fitting, the working pressures of the valves are related to the wall thickness of tubing applied. For specific working pressure of the valves, please refer to the allowable working pressures in FITOK Catalog Tubing.
2. Sizes and types listed are standard. Other sizes and types are available upon request. For details, please contact FITOK Group or our authorized distributors.
3. Dimensions are shown with FITOK tube fitting nuts finger-tight. All dimensions are for reference only and are subject to change. For dimensions not shown above, please contact FITOK Group or our authorized distributors.

Ordering Number Description

NBSS - FL8 - ML12 - 8WB - GYM - ASF2

Series	Body Material	Inlet Type	Inlet Size	Outlet Type	Outlet Size	Orifice Size	Stem Tip Material	Stem Tip Type	Packing Material	Panel Mounting	Handle	Flow Pattern	Special Application	Cleaning and Packaging							
NB	SS	316 SS	FNS	Female NPT	2	1/8"		Same as Inlet	7	0.16" (4.0 mm)		Same as Body		PTFE	No		Straight		FC-01		
	6L	316L SS	NS	Male NPT	4	1/4"		Specify in the same way as inlet Type and inlet Size	8	0.25" (6.4 mm)	W	Stellite		P	PEEK	Y	Yes	A	Angle	F2	FC-02
	S4	304 SS	FRT	Female BSPT	6	3/8" or 6 mm			9	0.39" (10 mm)	D5	Duplex 2205		G	Graphite						
	4L	304L SS	RT	Male BSPT	8	1/2" or 8 mm			6	0.59" (15 mm)	TI	Titanium									
	S1	321 SS	FMS	Female Metric Thread (for RG-M)	10	10 mm			0	0.71" (18 mm)	A20	Alloy 20									
	91	F91	MS	Male Metric Thread (for RG-M)	12	3/4" or 12 mm					M	Alloy 400									
	92	F92	FRP	Female BSPP (for RP)	14	14 mm or 14x2.5 mm or M14x1.5					INC	Alloy 600									
	D5	Duplex 2205	BP	Male BSPP (for RG)	16	1" or 16 mm or 16x2.8 mm					HC	Alloy C-276									
	TI	Titanium	TS	Fractional Tube Socket Weld	18	18 mm															
	A20	Alloy 20	MTS	Metric Tube Socket Weld	20	20 mm or M20 x 1.5															
	M	Alloy 400	TB	Fractional Tube Butt Weld	22	22 mm or M22 x 1.5															
	INC	Alloy 600	MTB	Metric Tube Butt Weld	24	M24 x 1.5															
	HC	Alloy C-276	PS	Pipe Socket Weld	25	25 mm															
	B	Brass	PB	Pipe Butt Weld	27	M27 x 2															
	CS	Carbon Steel	FL	Fractional Tube Fitting	28	28 mm															
	904L	904L SS	ML	Metric Tube Fitting																	
		UFB	Rotatable Fractional Tube Butt Weld																		
		UMB	Rotatable Metric Tube Butt Weld																		

NOTE: "Ordering Number Description" is a reference to understand the combination rules of FITOK product part number. Not all combinations are available.

- Standard thread pitch for metric threads are as follows:
M10 and below: 1 mm
M12 to M24: 1.5 mm
M27 and above: 2 mm
- Cleaning and Packaging:
FC-01: Standard cleaning and packaging for general industrial procedures.
FC-02: Special cleaning and packaging for wetted system components to ensure compliance with product cleanliness requirement of ASTM G93 Level C.

Nonrotating-stem Needle Valves

ND Series: Working pressure up to 3000 psig

NDH Series: Working pressure up to 5000 psig

Features

- ⦿ One-piece forged body
- ⦿ Straight and angle pattern
- ⦿ Compact design
- ⦿ Non-rotating stem
- ⦿ Specially designed handle to stop contamination from entering into the valve
- ⦿ Every valve leak tested with Nitrogen or compressed air at the maximum allowable working pressure
- ⦿ Working pressure up to:
 - ND Series—Stainless steel: 3000 psig (207 bar)
 - Brass: 3000 psig (207 bar)
 - NDH Series—Stainless steel: 5000 psig(345 bar)
- ⦿ Working temperature with stem tip:
 - PCTFE stem tip: -20°F to 200°F (-28°C to 93°C)
 - PEEK stem tip: -20°F to 400°F (-28°C to 204°C)
- ⦿ Working temperature with O-ring:
 - Fluorocarbon Rubber (FKM) : -20°F to 400°F (-28°C to 204°C)
 - Nitrile Butadiene Rubber (NBR) : -20°F to 212°F (-28°C to 100°C)
 - Ethylene Propylene Diene Rubber (EPDM): -20°F to 300°F (-28°C to 148°C)



Needle Valves
Metering Valves

Pressure vs. Temperature

ND Series

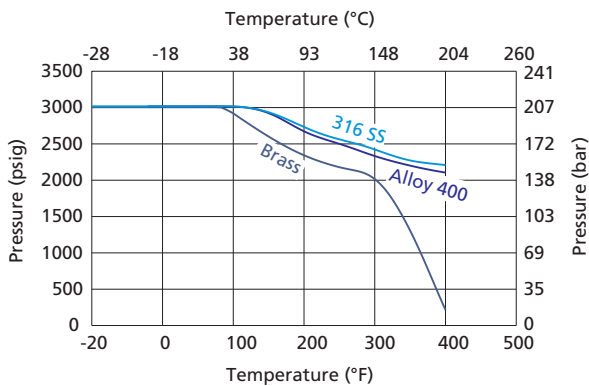

NDH Series

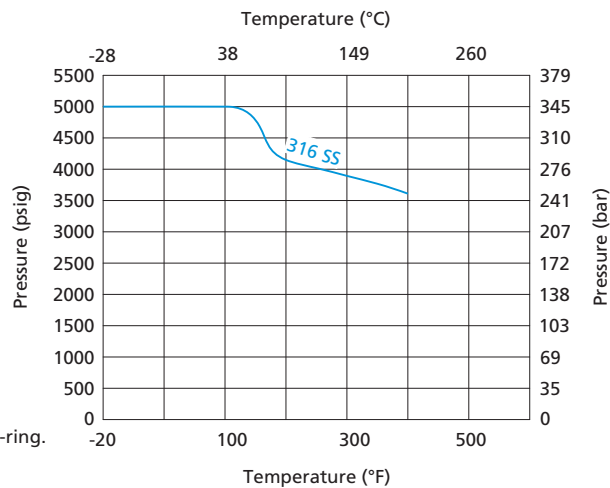

1. The graphs are based on PEEK stem tip and Fluorocarbon rubber (FKM) O-ring.
2. Contact FITOK Group or our authorized distributors for curve graph of other materials.

Flow Data at 100°F (38°C)

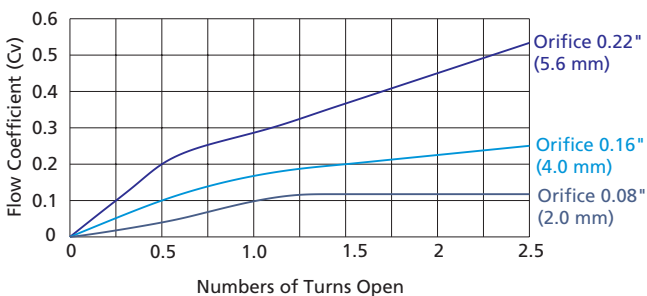

Standard Materials of Construction

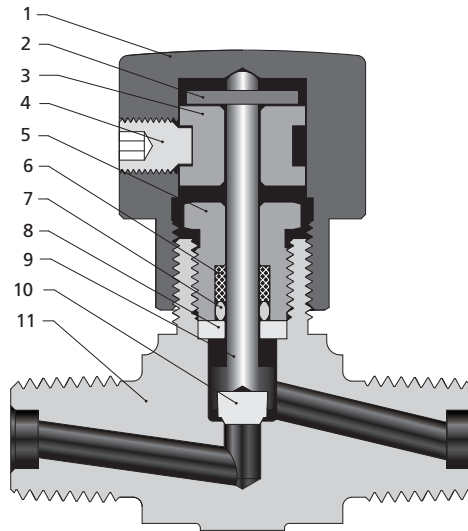

Item	Component	Valve Body Material				
		316 SS	304 SS	321 SS	Brass	Alloy 400
Material Grade/ASTM Specification						
1	Handle	Anodized aluminum				
2	Stop Pin	Stainless steel				
3	Spool	Aluminum				
4	Set Screw	Stainless steel				
5	Packing Bolt	304 SS/A479			Brass C36000/B16	Alloy 400/B164
6	Backup Ring	PTFE/D1710				
7	O-ring	Fluorocarbon Rubber (FKM), Nitrile Butadiene Rubber (NBR) or Ethylene Propylene Diene Rubber (EPDM)				
8	Washer	316 SS/A479				Alloy 400/B164
9	Stem	316 SS/A479				Alloy 400/B164
10	Stem Tip	PCTFE or PEEK				
11	Body	316 SS/A182	304 SS/A182	321 SS/A182	Brass C37700/B283	Alloy 400/B564
	Lubricant	Molybdenum disulfide-based				

Note: Contact FITOK Group or our authorized distributors for other materials.

Dimensions

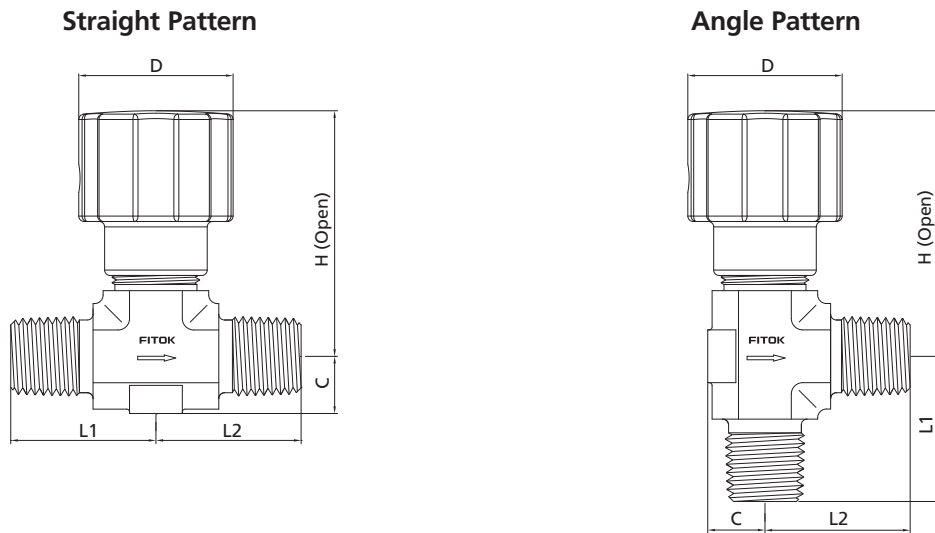

ND and NDH Series

Basic Ordering Number	Connection Type and Size		Orifice in.(mm)	Cv	Dimensions, in.(mm)				
	Inlet	Outlet			L1	L2	C	D	H
ND□□-NS2-5	1/8 Male NPT	1/8 Male NPT	0.08 (2.0)	0.12	0.81 (20.6)	0.81 (20.6)	0.32 (8.1)	1.06 (26.9)	1.86 (47.2)
ND□□-NS2-FL2-5	1/8 Male NPT	1/8" FITOK							
ND□□-FL2-5	1/8" FITOK	1/8" FITOK			1.10 (27.9)	1.10 (27.9)			
ND□□-ML3-5	3 mm FITOK	3 mm FITOK							
ND□□-NS4-7	1/4 Male NPT	1/4 Male NPT	0.16 (4.0)	0.27	0.98 (25.0)	0.98 (25.0)	0.39 (10.0)	1.13 (28.7)	1.86 (47.2)
ND□□-NS4-FL4-7	1/4 Male NPT	1/4 FITOK							
ND□□-FL4-7	1/4" FITOK	1/4" FITOK			1.13 (28.7)	1.13 (28.7)			
ND□□-ML6-7	6 mm FITOK	6 mm FITOK							
ND□□-ML8-7	8 mm FITOK	8 mm FITOK	1.18 (30.0)	1.18 (30.0)					
ND□□-FNS4-8	1/4 Female NPT	1/4 Female NPT	0.22 (5.6)	0.53	1.06 (26.9)	1.06 (26.9)	0.49 (12.5)	1.22 (31.0)	2.02 (51.3)
ND□□-NS6-8	3/8 Male NPT	3/8 Male NPT			1.12 (28.6)	1.12 (28.6)			
ND□□-FL6-8	3/8" FITOK	3/8" FITOK			1.29 (32.8)	1.29 (32.8)			
ND□□-FL8-8	1/2" FITOK	1/2" FITOK			1.40 (35.6)	1.40 (35.6)			
ND□□-ML10-8	10 mm FITOK	10 mm FITOK			1.30 (33.0)	1.30 (33.0)			
ND□□-ML12-8	12 mm FITOK	12 mm FITOK			1.40 (35.6)	1.40 (35.6)			
NDH□□-NS2-5	1/8 Male NPT	1/8 Male NPT	0.08 (2.0)	0.12	0.81 (20.6)	0.81 (20.6)	0.32 (8.1)	1.06 (26.9)	1.86 (47.2)
NDH□□-FL2-5	1/8" FITOK	1/8" FITOK							
NDH□□-ML3-5	3 mm FITOK	3 mm FITOK			1.10 (27.9)	1.10 (27.9)			
NDH□□-NS4-7	1/4 Male NPT	1/4 Male NPT	0.16 (4.0)	0.27	0.98 (25.0)	0.95 (25.0)	0.39 (10.0)	1.13 (28.7)	1.98 (50.2)
NDH□□-FL4-7	1/4" FITOK	1/4" FITOK							
NDH□□-ML6-7	6 mm FITOK	6 mm FITOK			1.13 (28.7)	1.13 (28.7)			

1. Connection type of "FITOK" means FITOK double ferrule tube fittings. When the connection type of valves is FITOK double ferrule tube fitting, the working pressures of the valves are related to the wall thickness of used applied. For specific working pressure of the valves, please refer to the allowable working pressures in FITOK Catalog Tubing.
2. Sizes and types listed are standard. Other sizes and types are available upon request. For details, please contact FITOK Group or our authorized distributors.
3. Dimensions are shown with FITOK tube fitting nuts finger-tight. All dimensions are for reference only and are subject to change. For dimensions not shown above, please contact FITOK Group or our authorized distributors.

Ordering Number Description

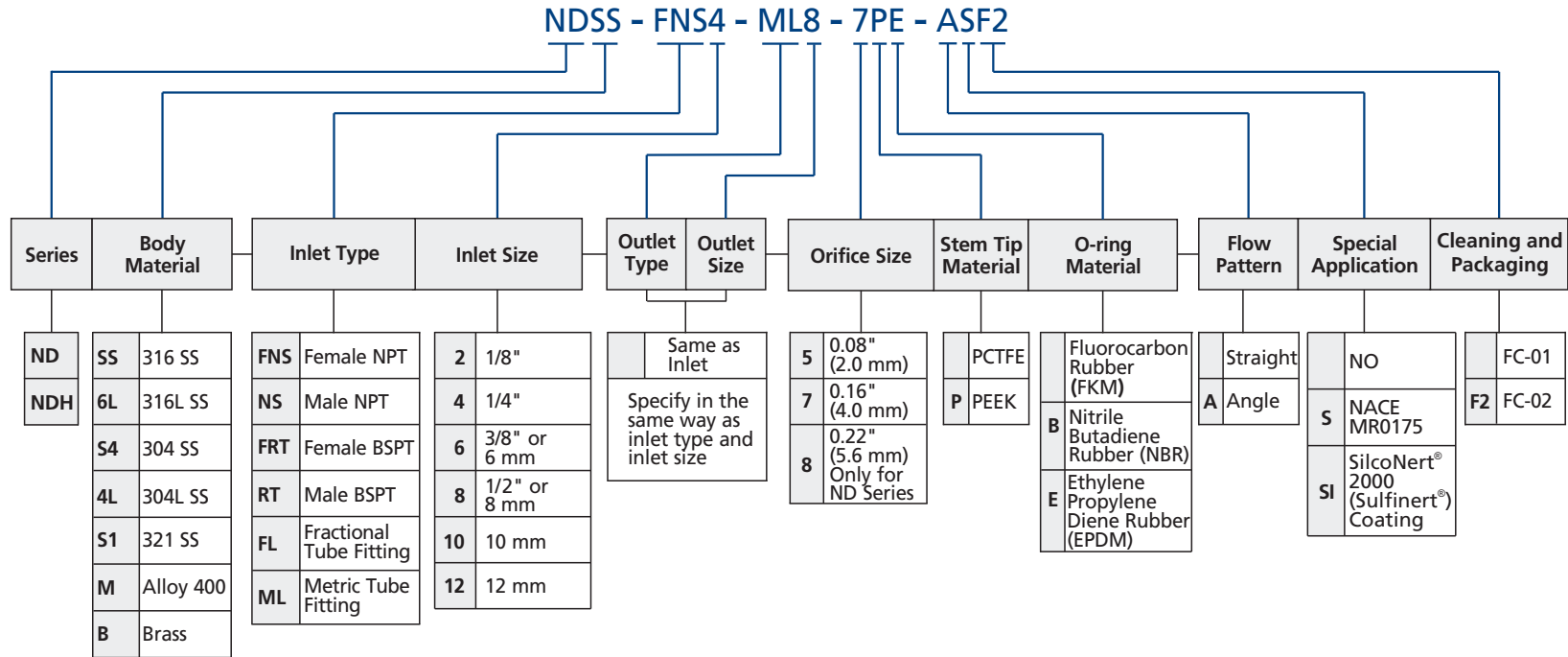

NOTE: "Ordering Number Description" is a reference to understand the combination rules of FITOK product part number. Not all combinations are available.

1. Cleaning and Packaging:
 - FC-01: Standard cleaning and packaging for general industrial procedures.
 - FC-02: Special cleaning and packaging for wetted system components to ensure compliance with product cleanliness requirement of ASTM G93 Level C.
2. Special Application:
 - Plural special application designators available in one ordering number, example: NDSS-NS4-7-SSI. SilcoNert® 2000 (Sulfinert®) coating: Wetted metal components SilcoNert® 2000 (Sulfinert®) coated.

Forged Body Needle Valves

NF Series: Working pressure up to 6000 psig

NFH Series: Working pressure up to 10000 psig

Features

- ⦿ One-piece forged body
- ⦿ Two-piece stem design: Upper stem threads cold rolled and lower stem hardened for high strength and smooth operation
- ⦿ Upper stem thread lubricant isolated from system media
- ⦿ Linear instead of rotary motion of the rising, non-rotating stem minimizes packing abrasion and reduces the friction between the seat and the tip
- ⦿ Panel mounting available
- ⦿ Steady and durable fastening of the handle by double lock-pins
- ⦿ Handles of different colors available
- ⦿ Every valve leak tested with Nitrogen or compressed air (NF Series) at the maximum allowable working pressure or with water (NFH Series) at 1.1 times the maximum allowable working pressure
- ⦿ Working pressure up to:
 - NF Series—Stainless steel: 6000 psig (414 bar)
 - Alloy C-276: 6000 psig (414 bar)
 - Alloy 400: 5000 psig (345 bar)
 - Titanium: 3500 psig (241 bar)
 - Brass: 3000 psig (207 bar)
- ⦿ NFH Series—Stainless steel: 10000 psig (690 bar)
- ⦿ Working temperature:
 - PTFE: -65°F to 450°F (-54°C to 232°C)
 - PEEK: -65°F to 500°F (-54°C to 260°C)
 - Graphite: -65°F to 1200°F (-54°C to 649°C)



Pressure vs. Temperature

NF Series

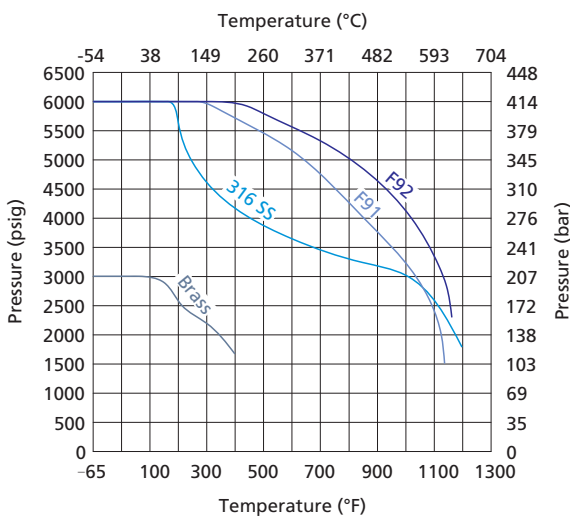

NFH Series

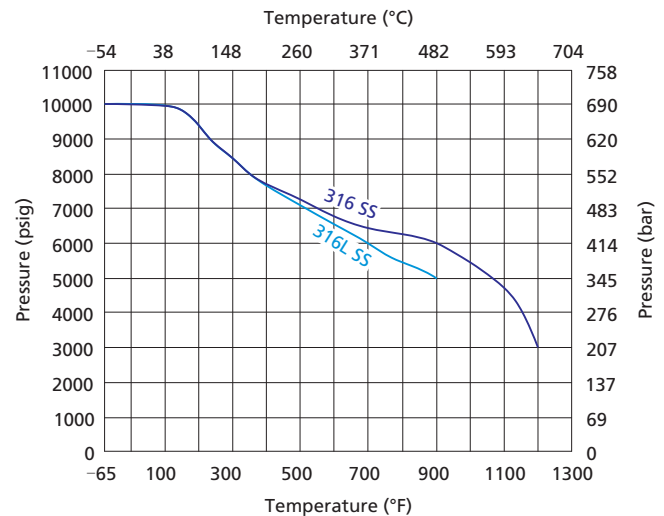

1. Graphs are based on graphite packing.
2. Soft tips are for NF Series only. Temperature rating is limited to 200°F (93°C) max. with PCTFE stem tip (soft tip).
3. Contact FITOK Group or our authorized distributors for curve graph of other materials.

Flow Data at 100°F (38°C)

Regulating Stem Tip

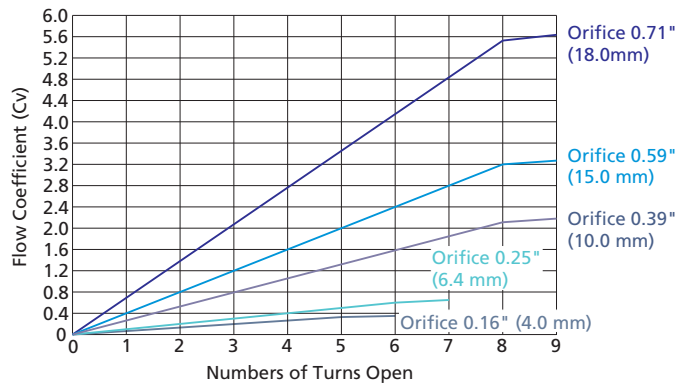

Standard Materials of Construction

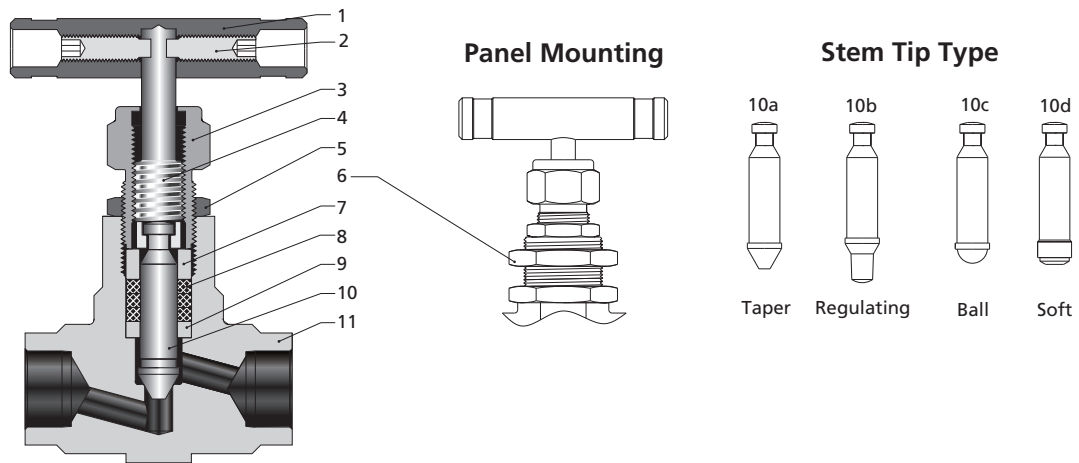

Item	Component	Valve Body Material		
		316 SS	F91	Brass
		Material Grade/ASTM Specification		
1	Handle	Anodized aluminum or stainless steel or black knob		
2	Set Screw	Galvanized carbon steel		
3	Packing Bolt	304 SS/A479	F91/A182	Brass C36000/B16
4	Upper Stem	316 SS/A479		
5	Lock Nut	Stainless steel	1020/A108	Brass C36000/B16
6	Panel Nut	Stainless steel	1020/A108	Brass C36000/B16
7	Gland	316 SS/A479		Brass C36000/B16
8	Packing	PTFE or PEEK or graphite		
9	Packing Washer	316 SS/A479		Brass C36000/B16
10a 10b 10c	Lower Stem	Hardened 316 SS/A479		
10d		Stem	316 SS/A479	
	Stem Tip	PTFE or PCTFE		
11	Body	316 SS/A182	F91/A182	Brass C37700/B283
	Seat	Same as body		
	Lubricant	Molybdenum disulfide-based		

Note: Contact FITOK Group or our authorized distributors for other materials.

Dimensions

Straight Pattern

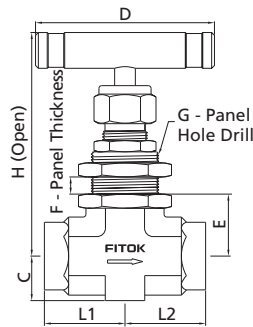

Angle Pattern

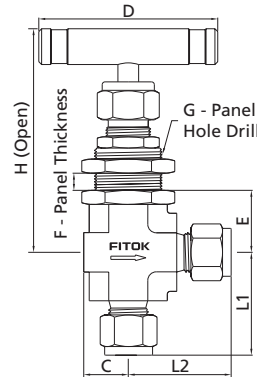

© NF Series Needle Valves are standard without panel mounting. To order needle valves with panel mounting as illustrated, add -Y to the ordering number. Example: NFSS-FNS2-7-Y

Dimensions of NF Series

Basic Ordering Number	Connection Type and Size	Connection Pressure at 100°F (38°C) psig (bar)	Orifice in.(mm)	Cv	Dimensions, in.(mm)											
					L1	L2	H	D	C	E	F	G				
		316 SS														
NF□□-FNS2-7	1/8 Female NPT	316 SS	0.16 (4.0)	0.35	1.00 (25.4)	1.00 (25.4)	2.85 (72.5)	2.17 (55)	0.49 (12.5)	0.71 (18.0)	0.25 (6.4)	0.77 (19.6)				
NF□□-FNS4-7	1/4 Female NPT				1.03 (26.2)	1.03 (26.2)										
NF□□-FL4-7	1/4" FITOK				1.22 (30.9)	1.22 (30.9)										
NF□□-ML6-7	6 mm FITOK				1.25 (31.75)	1.25 (31.75)										
NF□□-ML8-7	8 mm FITOK				1.03 (26.2)	1.03 (26.2)										
NF□□-NS4-7	1/4 Male NPT				1.13 (28.6)	1.13 (28.6)										
NF□□-NS6-7	3/8 Male NPT															
NF□□-FO4-7	1/4" Male FO															
NF□□-FR4-7	1/4" Male FR															
NF□□-FNS4-8	1/4 Female NPT				6000 (414)	0.25 (6.4)							0.85	1.13 (28.6)	1.13 (28.6)	3.38 (85.8)
NF□□-FNS6-8	3/8 Female NPT	1.42 (36.1)	1.42 (36.1)													
NF□□-NS6-8	3/8 Male NPT	1.44 (36.5)	1.44 (36.5)													
NF□□-FL6-8	3/8" FITOK	1.53 (38.9)	1.53 (38.9)													
NF□□-ML10-8	10 mm FITOK	1.56 (39.7)	1.56 (39.7)													
NF□□-ML12-8	12 mm FITOK	1.26 (32.0)	1.26 (32.0)													
NF□□-ML14-8	14 mm FITOK	1.50 (38.1)	1.50 (38.1)													
NF□□-FNS8-8	1/2 Female NPT	1.53 (38.9)	1.53 (38.9)													
NF□□-NS8-8	1/2 Male NPT															
NF□□-FL8-8	1/2" FITOK															
NF□□-TS6-8-G	3/8" Tube Socket Weld	1.13 (28.6)	1.13 (28.6)													
NF□□-TS8-8-G	1/2" Tube Socket Weld	1.50 (38.1)	1.50 (38.1)													
NF□□-MTS12-8-G	12 mm Tube Socket Weld	2.92 (74.1)	2.92 (74.1)													
NF□□-MTS14-8-G	14 mm Tube Socket Weld															
NF□□-MTS16-8-G	16 mm Tube Socket Weld															
NF□□-MTB14-8-G	14x2.5 mm Tube Butt Weld	1.13 (28.6)	1.13 (28.6)													
NF□□-MTB16-8-G	16x2.8 mm Tube Butt Weld	1.50 (38.1)	1.50 (38.1)													
NF□□-UMB14-8	14x2.5 mm Rotatable Tube Butt Weld															
NF□□-UMB16-8	16x2.8 mm Rotatable Tube Butt Weld															
NF□□-FO8-8	1/2" Male FO	1.13 (28.6)	1.13 (28.6)													
NF□□-FR8-8	1/2" Male FR	1.56 (39.7)	1.56 (39.7)													
NF□□-MS20-8	M20 x 1.5 Male Metric	1.50 (38.1)	1.50 (38.1)													

B-88 Needle Valves

Dimensions of NF Series

Basic Ordering Number	Connection Type and Size	Connection Pressure at 100°F (38°C) psig (bar)	Orifice in.(mm)	Cv	Dimensions, in.(mm)									
					L1	L2	H	D	C	E	F	G		
		316 SS												
NF□□-MS22-8	M22 x 1.5 Male Metric	6000 (414)	0.25 (6.4)	0.85	1.50 (38.1)	1.50 (38.1)	3.38 (85.8)	2.50 (63.5)	0.62 (15.8)	0.87 (22.0)	0.38 (9.7)	0.96 (24.4)		
NF□□-FNS8-9	1/2 Female NPT								0.80 (20.4)					
NF□□-NS12-9	3/4 Male NPT													
NF□□-FL12-9	3/4" FITOK		5800 (400)											
NF□□-ML14-9	14 mm FITOK		6000 (414)											
NF□□-ML16-9	16 mm FITOK		5800 (400)			1.97 (50.0)	1.97 (50.0)							
NF□□-ML18-9	18 mm FITOK		5370 (370)							0.76 (19.4)				
NF□□-ML20-9	20 mm FITOK		5510 (380)											
NF□□-MTS14-9-G	14 mm Tube Socket Weld	6000 (414)	0.39 (10.0)	2.18			3.86 (98.0)	3.50 (88.9)		1.10 (28.3)	0.38 (9.7)	1.08 (27.5)		
NF□□-MTS16-9-G	16 mm Tube Socket Weld													
NF□□-MTS18-9-G	18 mm Tube Socket Weld													
NF□□-TS12-9-G	3/4" Tube Socket Weld					1.56 (39.7)	1.56 (39.7)							
NF□□-PS8-9-G	1/2 Pipe Socket Weld									0.80 (20.4)				
NF□□-MTB16-9-G	16x2.25 mm Tube Butt Weld										0.76 (19.4)			
NF□□-UMB14-9	14x2.5 mm Rotatable Tube Butt Weld					2.98 (75.7)	2.98 (75.7)							
NF□□-UMB16-9	16x2.8 mm Rotatable Tube Butt Weld					1.56 (39.7)	1.56 (39.7)							
NF□□-MS27-9	M27 x 2 Male Metric													
NF□□-FNS12-6	3/4 Female NPT													
NF□□-TS16-6-G	1" Tube Socket Weld													
NF□□-MTS25-6-G	25 mm Tube Socket Weld				1.97 (50.0)	1.97 (50.0)								
NF□□-MTS28-6-G	28 mm Tube Socket Weld	5500 (379)					5.00 (127)	5.00 (127)	1.08 (27.5)	1.61 (41.0)	0.38 (9.7)	1.45 (36.8)		
NF□□-PS12-6-G	3/4 Pipe Socket Weld	6000 (414)												
NF□□-PB12-6-G	3/4xSCH80 Pipe Butt Weld			0.59 (15.0)	3.27									
NF□□-FL12-6	3/4" FITOK		5800 (400)			2.35 (59.7)	2.35 (59.7)							
NF□□-ML20-6	20 mm FITOK	5510 (380)												
NF□□-TS16-0-G	1" Tube Socket Weld	6000 (414)												
NF□□-MTS25-0-G	25 mm Tube Socket Weld													
NF□□-MTS28-0-G	28 mm Tube Socket Weld	5500 (379)	0.71 (18.0)	5.65	1.97 (50.0)	1.97 (50.0)	5.33 (135.4)	5.00 (127)	1.08 (27.5)	1.61 (41.0)	0.38 (9.7)	1.45 (36.8)		
NF□□-PS12-0-G	3/4 Pipe Socket Weld	6000 (414)												
NF□□-PB16-0-G	1xSCH80 Pipe Butt Weld	5720 (394)												

1. Connection type of "FITOK" means FITOK double ferrule tube fittings. When the connection type of valves is FITOK double ferrule tube fitting, the working pressures of the valves are related to the wall thickness of tubing applied. For specific working pressure of the valves, please refer to the allowable working pressures in FITOK Catalog Tubing.
2. Connection type of "FO" means O-ring face seal fittings. "FR" means metal gasket face seal fittings.
3. Sizes and types listed are standard. Other sizes and types are available upon request. For details, please contact FITOK Group or our authorized distributors.
4. Dimensions are shown with FITOK tube fitting nuts finger-tight. All dimensions are for reference only and are subject to change. For dimensions not shown above, please contact FITOK Group or our authorized distributors.

Straight Pattern

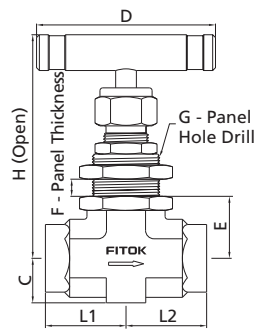

Angle Pattern

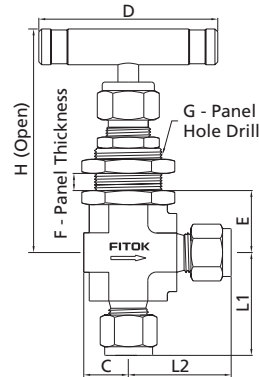

© NFH Series Needle Valves are standard without panel mounting. To order needle valves with panel mounting as illustrated, add -Y to the ordering number. Example: NFHSS-FNS2-7-Y

Dimensions of NFH Series

Basic Ordering Number	Connection Type and Size	Connection Pressure at 100°F (38°C) psig (bar)	Orifice in.(mm)	Cv	Dimensions, in.(mm)							
					Inlet/Outlet	316 SS	L1	L2	H	D	C	E
NFH□□-FL4-7	1/4" FITOK	10000 (690)	0.16 (4.0)	0.35	1.41 (35.8)	1.41 (35.8)	2.85 (72.5)	2.17 (55)	0.62 (15.8)	0.76 (19.4)	0.25 (6.4)	0.77 (19.6)
NFH□□-FNS2-7	1/8 Female NPT				1.00 (25.4)	1.00 (25.4)						
NFH□□-FNS4-7	1/4 Female NPT				1.06 (26.2)	1.06 (26.2)						
NFH□□-NS4-7	1/4 Male NPT				1.22 (30.9)	1.22 (30.9)						
NFH□□-FNS4-NS4-7	1/4 Female NPT/ 1/4 Male NPT				1.06 (26.2)	1.22 (30.9)						
NFH□□-TS4-7-G	1/4" Tube Socket Weld				1.06 (26.2)	1.06 (26.2)						
NFH□□-FNS4-8	1/4 Female NPT	9000 (620)	0.25 (6.4)	0.85	1.12 (28.6)	1.12 (28.6)	3.38 (85.8)	2.50 (63.5)	0.76 (19.4)	0.87 (22.0)	0.38 (9.7)	0.96 (24.4)
NFH□□-FNS6-8	3/8 Female NPT				1.50 (38.1)	1.50 (38.1)						
NFH□□-NS6-8	3/8 Male NPT	10000 (690)	0.39 (10.0)	2.18	1.56 (39.7)	1.56 (39.7)	3.86 (98.0)	3.50 (88.9)	0.76 (19.4)	1.10 (28.3)	0.38 (9.7)	1.08 (27.5)
NFH□□-TS8-9-G	1/2" Tube Socket Weld								0.80 (20.4)			
NFH□□-MTS16-9-G	16 mm Tube Socket Weld								0.80 (20.4)			
NFH□□-MTB25-9-G	25×5.5 mm Tube Butt Weld						0.88 (22.2)					
NFH□□-FNS8-9	1/2 Female NPT						4.16 (105.7)	0.88 (22.2)				

1. Connection type of "FITOK" means FITOK double ferrule tube fittings. When the connection type of valves is FITOK double ferrule tube fitting, the working pressures of the valves are related to the wall thickness of tubing applied. For specific working pressure of the valves, please refer to the allowable working pressures in FITOK Tubing catalog.
2. Sizes and types listed are standard. Other sizes and types are available upon request. For details, please contact FITOK Group or our authorized distributors.
3. Dimensions are shown with FITOK tube fitting nuts finger-tight. All dimensions are for reference only and are subject to change. For dimensions not shown above, please contact FITOK Group or our authorized distributors.

Ordering Number Description

NFS4 - TS16 - MTS25 - 6WR - GYM - ASF2

Series	Body Material	Inlet Type	Inlet Size	Outlet Type	Outlet Size	Orifice Size	Stem Tip Material	Stem Tip Type	Packing Material	Panel Mounting	Handle	Flow Pattern	Special Application	Cleaning and Packaging
NF	SS	316 SS	FNS Female NPT	2	1/8"	7	0.16" (4.0 mm)	Same as Body	Taper	No		Straight		FC-01
NFH	6L	316L SS	NS Male NPT	4	1/4"	8	0.25" (6.4 mm)	W	Regulating	Y	Yes	A		F2
	S4	304 SS	FRT Female BSPT	6	3/8" or 6 mm	9	0.39" (10 mm)	D5	Ball					
	4L	304L SS	RT Male BSPT	8	1/2" or 8 mm	6	0.59" (15 mm)	TI	Soft Tip-PTFE					
	S1	321 SS	FMS Female Metric Thread (for RG-M)	10	10 mm	0	0.71" (18 mm)	A20	Soft Tip-PCTFE				NO	
	91	F91	MS Male Metric Thread (for RG-M)	12	3/4" or 3/4" xSCH80 or 12 mm			M	Soft stem tip only for NF Series Needle Valves with the orifice 0.16"/4.0mm, 0.25"/6.4mm and 0.39"/10mm			I	NACE MR0175	
	92	F92	FRP Female BSPP (for RP)	14	14 mm or 14x2.5 mm or M14x1.5			INC				J	SilcoNert® 2000 (Sulfinert®) Coating	
	D5	Duplex 2205	BP Male BSPP (for RG)	16	1" or 1" xSCH80 or 16 mm or 16x2.25 mm or 16x2.8 mm			HC				M		
	TI	Titanium	TS Fractional Tube Socket Weld	18	18 mm							B		
	A20	Alloy 20	MTS Metric Tube Socket Weld	20	20 mm or M20 x 1.5									
	M	Alloy 400	TB Fractional Tube Butt Weld	22	22 mm or M22 x 1.5									
	INC	Alloy 600	MTB Metric Tube Butt Weld	24	M24 x 1.5									
	HC	Alloy C-276	PS Pipe Socket Weld	25	25 mm or 25x5.5 mm									
	B	Brass	PB Pipe Butt Weld	27	M27 x 2									
	CS	Carbon Steel	FL Fractional Tube Fitting	28	28 mm									
	904L	904L SS	ML Metric Tube Fitting											
			UFB Rotatable Fractional Tube Butt Weld											
			UMB Rotatable Metric Tube Butt Weld											
			FO Male FO Fitting											
			FR Male FR Fitting											

NOTE: "Ordering Number Description" is a reference to understand the combination rules of FITOK product part number. Not all combinations are available.

- Standard thread pitch for metric threads are as follows:
M10 and below: 1 mm
M12 to M24: 1.5 mm
M27 and above: 2 mm
- FO means FITOK O-ring face seal fittings.
- FR means FITOK metal gasket face seal fittings.
- Cleaning and Packaging:
FC-01: Standard cleaning and packaging for general industrial procedures.
FC-02: Special cleaning and packaging for wetted system components to ensure compliance with product cleanliness requirement of ASTM G93 Level C.
- Special Application:
Plural special application designators available in one ordering number, example: NFSS-NS4-7-SSI. SilcoNert® 2000 (Sulfinert®) coating: Wetted metal components SilcoNert® 2000 (Sulfinert®) coated.

Integral Bonnet Needle Valves

NG Series: Working pressure up to 3000 psig

NGH Series: Working pressure up to 5000 psig

Features

- ⦿ One-piece forged body
- ⦿ Easy external adjustments by packing nut
- ⦿ Live-loaded packing system
- ⦿ Handles of different colors available
- ⦿ Compact design
- ⦿ Panel mounting available
- ⦿ Every valve leak tested with Nitrogen or compressed air at the maximum allowable working pressure
- ⦿ Working pressure up to:
 - NG Series—Stainless steel, Brass, Alloy 400: 3000 psig (207 bar)
 - NGH Series—Stainless steel: 5000 psig (345 bar)
- ⦿ Working temperature:
 - PTFE: -65°F to 450°F (-54°C to 232°C)
 - PEEK: -65°F to 500°F (-54°C to 260°C)



Needle Valves
Metering Valves

Pressure vs. Temperature

NG Series

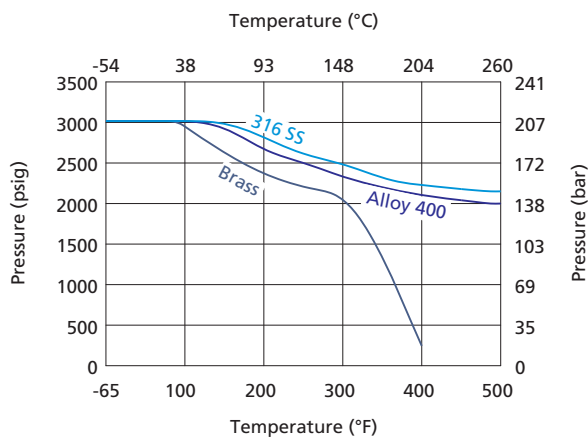

NGH Series

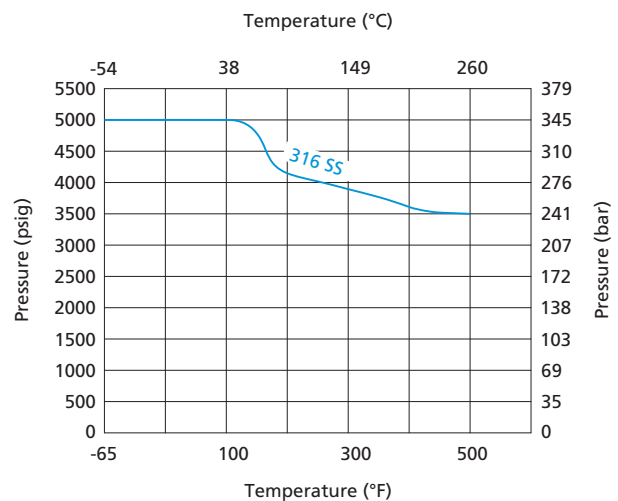

1. Graphs are based on PEEK packing.
2. Temperature rating is limited to 200°F (93°C) max with PCTFE stem tip (soft tip).
3. Contact FITOK Group or our authorized distributors for curve graph of other materials.

Flow Data at 100°F (38°C)

Regulating Stem Tip

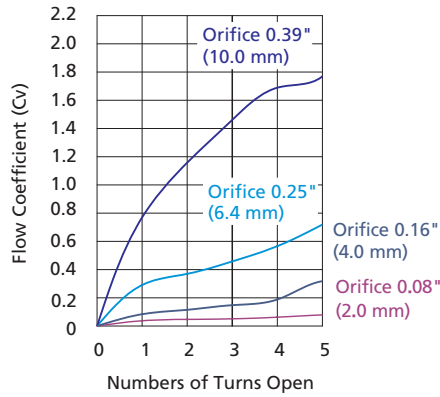

Standard Materials of Construction

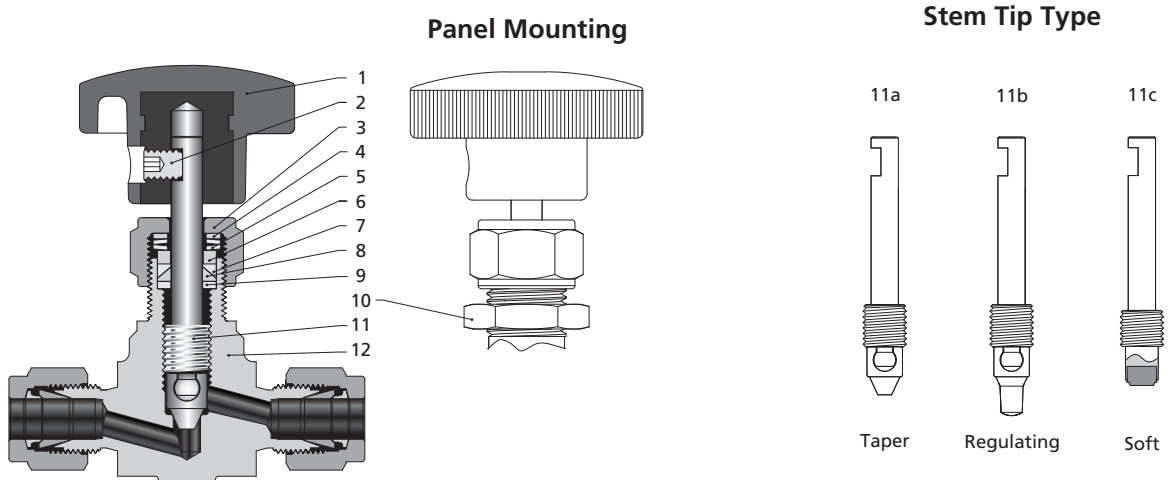

Item	Component	Valve Body Material		
		316 SS	Brass	Alloy 400
		Material Grade/ASTM Specification		
1	Handle	Black knob (aluminum or nylon with copper insert), aluminum alloy or stainless steel bar handle		
2	Set Screw	Galvanized carbon steel		
3	Packing Bolt	304 SS/A479	Brass C36000/B16	304 SS/A479
4	Washer	316 SS/A479		
5	Packing Spring	S17700/A693		
6	Washer	316 SS/A479		
7	Upper Packing	PTFE/PEEK		
8	Lower Packing			
9	Packing Washer	316 SS/A479	Alloy 400/B164	
10	Panel Nut	Stainless steel	Brass C36000/B16	Stainless steel
11a	Stem	316 SS/A479		Alloy 400/B164
11b	Stem Tip	Hardened 316 SS/A479		Alloy 400/B164
11c	Stem	316 SS/A479		Alloy 400/B164
	Stem Tip	PCTFE or PEEK		
12	Body	316 SS/A182	Brass C37700/B283	Alloy 400/B564
	Lubricant	Molybdenum disulfide-based		

Note: Contact FITOK Group or our authorized distributors for other materials.

Dimensions

Straight Pattern

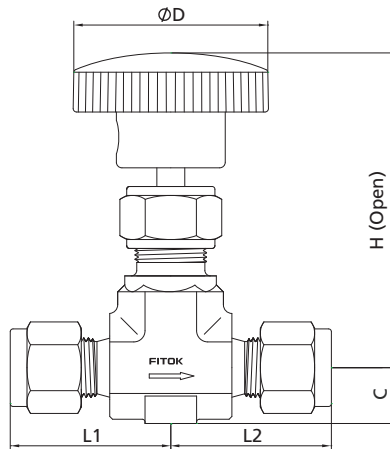

Angle Pattern

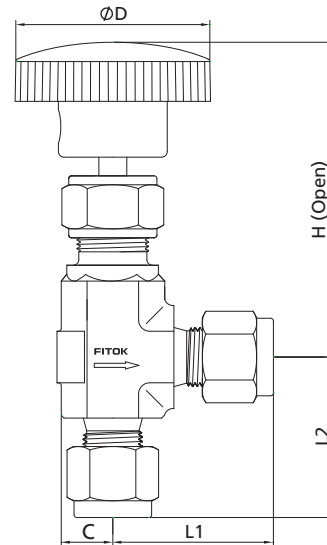

Dimensions of NG Series

Basic Ordering Number	Connection Type and Size		Orifice in.(mm)	Cv	Dimensions, in.(mm)						
	Inlet	Outlet			L1	L2	C	D	H		
NG□□-NS2-5	1/8 Male NPT	1/8 Male NPT	0.08 (2.0)	0.09	0.75 (19.05)	0.75 (19.05)	0.32 (8.2)	1.00 (25.4)	2.30 (58.4)		
NG□□-FNS2-5	1/8 Female NPT	1/8 Female NPT			0.81 (20.6)	0.81 (20.6)					
NG□□-FL2-5	1/8" FITOK	1/8" FITOK			0.98 (25.0)	0.98 (25.0)					
NG□□-ML3-5	3 mm FITOK	3 mm FITOK									
NG□□-FNS2-7	1/8 Female NPT	1/8 Female NPT	0.16 (4.0)	0.35	0.81 (20.6)	0.81 (20.6)	0.39 (10.0)	1.38 (35.0)	2.46 (62.5)		
NG□□-NS4-7	1/4 Male NPT	1/4 Male NPT			0.98 (25.0)	0.98 (25.0)					
NG□□-FL4-7	1/4" FITOK	1/4" FITOK			1.13 (28.7)	1.13 (28.7)					
NG□□-ML6-7	6 mm FITOK	6 mm FITOK			1.17 (29.7)	1.17 (29.7)					
NG□□-ML8-7	8 mm FITOK	8 mm FITOK			2.24 (57.0)	2.24 (57.0)					
NG□□-UMB6-7	6x1.8 mm Rotatable Tube Butt Weld	6x1.8 mm Rotatable Tube Butt Weld									
NG□□-FNS4-8	1/4 Female NPT	1/4 Female NPT	0.25 (6.4)	0.70	1.06 (26.9)	1.06 (26.9)	0.49 (12.5)	1.88 (47.8)	2.85 (72.4)		
NG□□-FNS6-8	3/8 Female NPT	3/8 Female NPT			1.12 (28.4)	1.12 (28.4)	0.62 (15.8)		2.90 (73.7)		
NG□□-NS6-8	3/8 Male NPT	3/8 Male NPT			1.12 (28.4)	1.12 (28.4)	0.49 (12.5)		2.85 (72.4)		
NG□□-NS8-8	1/2 Male NPT	1/2 Male NPT			1.50 (38.1)	1.50 (38.1)	0.62 (15.8)		2.90 (73.7)		
NG□□-FL6-8	3/8" FITOK	3/8" FITOK			1.29 (32.8)	1.29 (32.8)	0.49 (12.5)		2.85 (72.4)		
NG□□-FL8-8	1/2" FITOK	1/2" FITOK			1.40 (35.6)	1.40 (35.6)					
NG□□-ML10-8	10 mm FITOK	10 mm FITOK			1.30 (33.0)	1.30 (33.0)					
NG□□-ML12-8	12 mm FITOK	12 mm FITOK			1.40 (35.6)	1.40 (35.6)					
NG□□-ML14-8	14 mm FITOK	14 mm FITOK			1.56 (39.7)	1.56 (39.7)	0.62 (15.8)		2.90 (73.7)		
NG□□-MS20-8	M20 x 1.5 Male Metric	M20 x 1.5 Male Metric			1.50 (38.1)	1.50 (38.1)					
NG□□-UMB10-8	10x2.2 mm Rotatable Tube Butt Weld	10x2.2 mm Rotatable Tube Butt Weld					2.60 (66.0)		2.60 (66.0)	0.49 (12.5)	2.85 (72.4)
NG□□-UMB14-8	14x2.5 mm Rotatable Tube Butt Weld	14x2.5 mm Rotatable Tube Butt Weld									

Dimensions of NG Series

Basic Ordering Number	Connection Type and Size		Orifice in.(mm)	Cv	Dimensions, in.(mm)				
	Inlet	Outlet			L1	L2	C	D	H
NG□□-FNS8-9-L	1/2 Female NPT	1/2 Female NPT	0.39 (10.0)	1.80	1.50 (38.1)	1.50 (38.1)	0.76 (19.4)	3.50 (88.9)	3.37 (85.7)
NG□□-FNS12-9-L	3/4 Female NPT	3/4 Female NPT			1.56 (39.7)	1.56 (39.7)	0.80 (20.4)		
NG□□-NS12-9-L	3/4 Male NPT	3/4 Male NPT			1.56 (39.7)	1.56 (39.7)	0.76 (19.4)		
NG□□-FL8-9-L	1/2" FITOK	1/2" FITOK							
NG□□-FL12-9-L	3/4" FITOK	3/4" FITOK			1.90 (48.3)	1.90 (48.3)	0.76 (19.4)		
NG□□-ML14-9-L	14 mm FITOK	14 mm FITOK							

1. Connection type of "FITOK" means FITOK double ferrule tube fittings. When the connection type of valves is FITOK double ferrule tube fitting, the working pressures of the valves are related to the wall thickness of used tubing. For specific working pressure of the valves, please refer to the allowable working pressures in FITOK Catalog Tubing.
2. Sizes and types listed are standard. Other sizes and types are available upon request. For details, please contact FITOK Group or our authorized distributors.
3. Dimensions are shown with FITOK tube fitting nuts finger-tight. All dimensions are for reference only and are subject to change. For dimensions not shown above, please contact FITOK Group or our authorized distributors.

Panel Mount Dimensions of NG Series

Orifice in.(mm)	Dimensions, in.(mm)	
	E	F
0.08 (2.0)	0.44 (11.2)	0.47 (11.9)
0.16 (4.0)	0.44 (11.2)	0.53 (13.5)
0.25 (6.4)	0.50 (12.7)	0.78 (19.8)
0.39 (10.0)	0.75 (19.1)	1.03 (26.2)

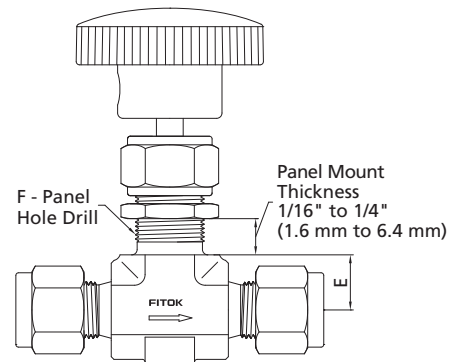

1. NG Series Needle Valves are standard without panel mounting.
2. To order needle valves with panel mounting as illustrated, add -Y to the ordering number. Example: NGSS-NS2-5-Y

Straight Pattern

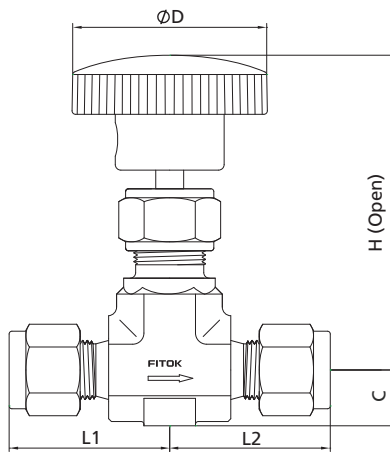

Angle Pattern

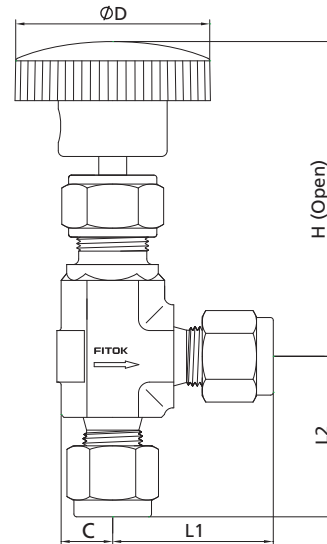

Dimensions of NGH Series

Basic Ordering Number	Connection Type and Size		Orifice in.(mm)	Cv	Dimensions, in.(mm)				
	Inlet	Outlet			L1	L2	C	D	H
NGH□□-NS2-5	1/8 Male NPT	1/8 Male NPT	0.08 (2.0)	0.09	0.75 (19.0)	0.75 (19.0)	0.32 (8.2)	1.00 (25.4)	2.30 (58.4)
NGH□□-FNS2-5	1/8 Female NPT	1/8 Female NPT			0.81 (20.6)	0.81 (20.6)			
NGH□□-FL2-5	1/8" FITOK	1/8" FITOK			0.98 (25.0)	0.98 (25.0)			
NGH□□-ML3-5	3 mm FITOK	3 mm FITOK							
NGH□□-FNS2-7	1/8 Female NPT	1/8 Female NPT	0.16 (4.0)	0.35	0.81 (20.6)	0.81 (20.6)	0.39 (10.0)	1.38 (35.0)	2.46 (62.5)
NGH□□-NS4-7	1/4 Male NPT	1/4 Male NPT			0.98 (25.0)	0.98 (25.0)			
NGH□□-FL4-7	1/4" FITOK	1/4" FITOK			1.13 (28.7)	1.13 (28.7)			
NGH□□-ML6-7	6 mm FITOK	6 mm FITOK			1.17 (29.7)	1.17 (29.7)			
NGH□□-ML8-7	8 mm FITOK	8 mm FITOK							
NGH□□-UMB6-7	6x1.8 mm Rotatable Tube Butt Weld	6x1.8 mm Rotatable Tube Butt Weld			2.24 (57.0)	2.24 (57.0)			
NGH□□-FNS4-8	1/4 Female NPT	1/4 Female NPT	0.25 (6.4)	0.70	1.06 (26.9)	1.06 (26.9)	0.49 (12.5)	1.88 (47.8)	2.85 (72.4)
NGH□□-FNS6-8	3/8" Female NPT	3/8" Female NPT					0.62 (15.8)		2.90 (73.7)
NGH□□-NS6-8	3/8 Male NPT	3/8 Male NPT			1.12 (28.4)	1.12 (28.4)	0.49 (12.5)		2.85 (72.4)
NGH□□-NS8-8	1/2 Male NPT	1/2 Male NPT			1.50 (38.1)	1.50 (38.1)	0.62 (15.8)		2.90 (73.7)
NGH□□-FL6-8	3/8" FITOK	3/8" FITOK			1.29 (32.8)	1.29 (32.8)	0.49 (12.5)		2.85 (72.4)
NGH□□-FL8-8	1/2" FITOK	1/2" FITOK			1.40 (35.6)	1.40 (35.6)			
NGH□□-ML10-8	10 mm FITOK	10 mm FITOK			1.30 (33.0)	1.30 (33.0)			
NGH□□-ML12-8	12 mm FITOK	12 mm FITOK			1.40 (35.6)	1.40 (35.6)			
NGH□□-ML14-8	14 mm FITOK	14 mm FITOK			1.56 (39.7)	1.56 (39.7)	0.62 (15.8)		2.90 (73.7)
NGH□□-MS20-8	M20 x 1.5 Male Metric	M20 x 1.5 Male Metric			1.50 (38.1)	1.50 (38.1)			
NGH□□-UMB10-8	10x2.2 mm Rotatable Tube Butt Weld	10x2.2 mm Rotatable Tube Butt Weld			2.60 (66.0)	2.60 (66.0)	0.49 (12.5)	2.85 (72.4)	
NGH□□-UMB14-8	14x2.5 mm Rotatable Tube Butt Weld	14x2.5 mm Rotatable Tube Butt Weld							

Dimensions of NGH Series

Basic Ordering Number	Connection Type and Size		Orifice in.(mm)	Cv	Dimensions, in.(mm)				
	Inlet	Outlet			L1	L2	C	D	H
NGH□□-FNS8-9-L	1/2 Female NPT	1/2 Female NPT	0.39 (10.0)	1.80	1.50 (38.1)	1.50 (38.1)	0.76 (19.4)	3.50 (88.9)	3.37 (85.7)
NGH□□-NS12-9-L	3/4 Male NPT	3/4 Male NPT			1.56 (39.7)	1.56 (39.7)	0.76 (19.4)		
NGH□□-FL8-9-L	1/2" FITOK	1/2" FITOK			1.90 (48.3)	1.90 (48.3)	0.76 (19.4)		
NGH□□-FL12-9-L	3/4" FITOK	3/4" FITOK							
NGH□□-ML14-9-L	14 mm FITOK	14 mm FITOK							

1. Connection type of "FITOK" means FITOK double ferrule tube fittings. When the connection type of valves is FITOK double ferrule tube fitting, the working pressures of the valves are related to the wall thickness of tubing applied. For specific working pressure of the valves, please refer to the allowable working pressures in FITOK Catalog Tubing.
2. Sizes and types listed are standard. Other sizes and types are available upon request. For details, please contact FITOK Group or our authorized distributors.
3. Dimensions are shown with FITOK tube fitting nuts finger-tight. All dimensions are for reference only and are subject to change. For dimensions not shown above, please contact FITOK Group or our authorized distributors.

Needle Valves
Metering Valves

Panel Mount Dimensions of NGH Series

Orifice in.(mm)	Dimensions, in.(mm)	
	E	F
0.08 (2.0)	0.44 (11.2)	0.47 (11.9)
0.16 (4.0)	0.44 (11.2)	0.53 (13.5)
0.25 (6.4)	0.50 (12.7)	0.78 (19.8)
0.39 (10.0)	0.75 (19.1)	1.03 (26.2)

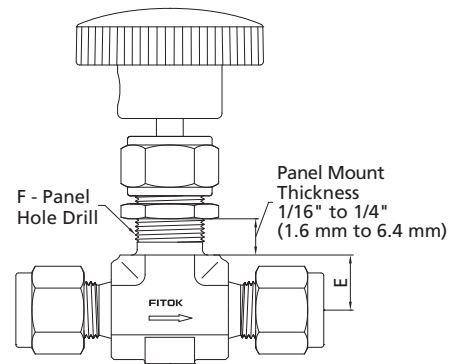

1. NGH Series Needle Valves are standard without panel mounting.
2. To order needle valves with panel mounting as illustrated, add -Y to the ordering number. Example: NGHSS-NS2-5-Y

Ordering Number Description

NGS4 - FNS8 - FL8 - 9P - PYM - ASF2

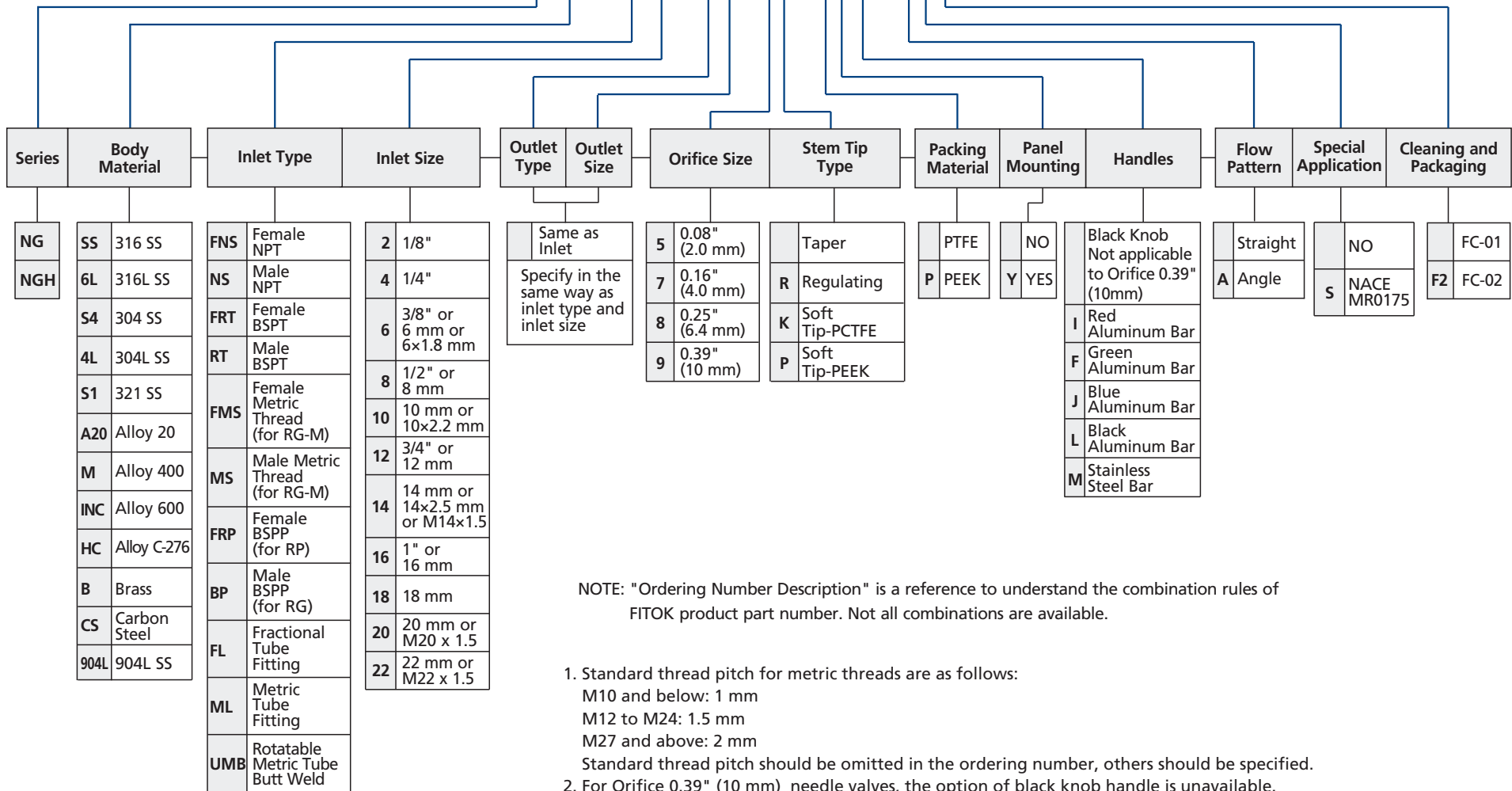

NOTE: "Ordering Number Description" is a reference to understand the combination rules of FITOK product part number. Not all combinations are available.

- Standard thread pitch for metric threads are as follows:
 M10 and below: 1 mm
 M12 to M24: 1.5 mm
 M27 and above: 2 mm
 Standard thread pitch should be omitted in the ordering number, others should be specified.
- For Orifice 0.39" (10 mm) needle valves, the option of black knob handle is unavailable. If handle designator is void, a black anodized Aluminum bar handle should be equipped.
- Cleaning and Packaging:
 FC-01: Standard cleaning and packaging for general industrial procedures.
 FC-02: Special cleaning and packaging for wetted system components to ensure compliance with product cleanliness requirement of ASTM G93 Level C.

Rising Plug Valves

NR Series

NRG (with gauge port) Series

Features

- ⦿ Cold drawn square bar as body material
- ⦿ Nonrotating stem for longer seat life
- ⦿ Roddable, straight through flow path for maximum flow with minimum pressure drop
- ⦿ Stem thread lubricant isolated from system media
- ⦿ Replaceable seat and stem tip design
- ⦿ Stem thread protected from outside contamination by PTFE ring in the gland
- ⦿ Panel mounting available
- ⦿ Handles of different colors available
- ⦿ Every valve leak tested with Nitrogen or compressed air at the maximum allowable working pressure
- ⦿ Working pressure up to:
 - Stainless steel: 6000 psig (414 bar)
 - Alloy 400: 5000 psig (345 bar)
- ⦿ Working temperature with seat:
 - Acetal: -20°F to 250°F (-28°C to 121°C)
 - PEEK: -20°F to 450°F (-28°C to 232°C)
- ⦿ Working temperature with O-ring:
 - Fluorocarbon Rubber (FKM): -20°F to 400°F (-28°C to 204°C)
 - Nitrile Butadiene Rubber (NBR): -20°F to 212°F (-28°C to 100°C)
 - Ethylene Propylene Diene Rubber (EPDM): -20°F to 300°F (-28°C to 148°C)



Pressure vs. Temperature

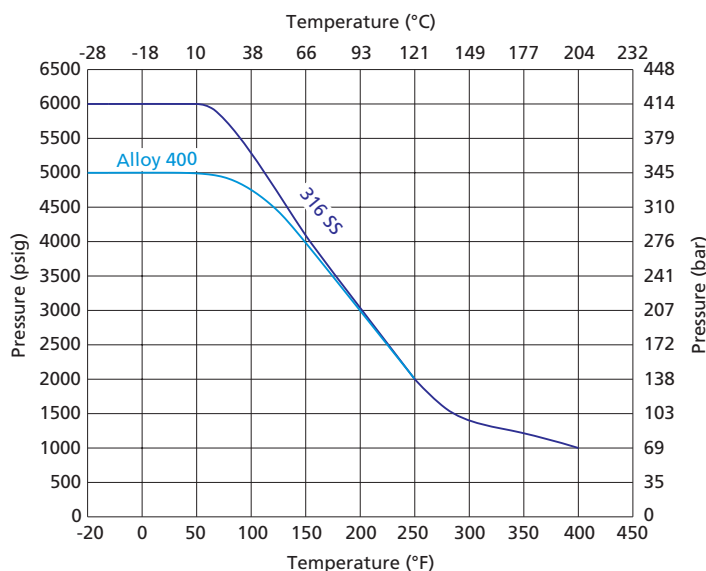

Flow Data at 100°F (38°C)

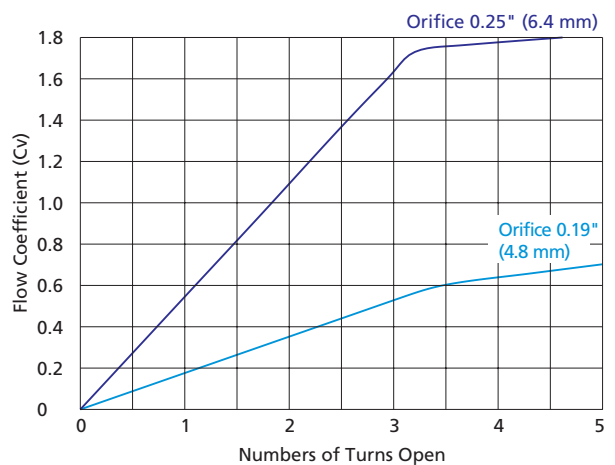

1. Graphs are based on PEEK seat and Fluorocarbon(FKM) O-ring.
2. Contact FITOK Group or our authorized distributors for curve graph of other materials.

Standard Materials of Construction

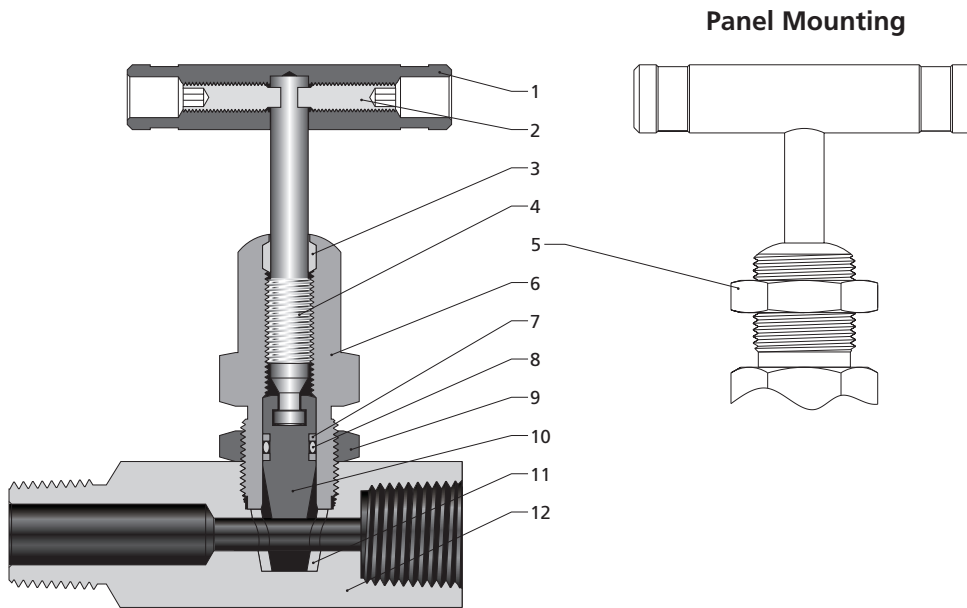

Item	Component	Valve Body Material			
		316 SS	304 SS	321 SS	Alloy 400
		Material Grade/ASTM Specification			
1	Handle	Anodized aluminum or stainless steel or black knob			
2	Set Screw	Galvanized carbon steel			
3	Wiper Ring	PTFE/D1710			
4	Upper Stem	316 SS/A479			Alloy 400/B164
5	Panel Nut	Stainless steel			
6	Bonnet	316 SS/A479	304 SS/A479	321 SS/A479	Alloy 400/B164
7	Backup Ring	PTFE/D1710			
8	O-ring	Fluorocarbon Rubber (FKM), Nitrile Butadiene Rubber (NBR) or Ethylene Propylene Diene Rubber (EPDM)			
9	Lock Nut	Stainless steel			
10	Stem Tip	316 SS/A479	304 SS/A479	321 SS/A479	Alloy 400/B164
11	Seat	Acetal or PEEK			
12	Body	316 SS/A479	304 SS/A479	321 SS/A479	Alloy 400/B164
	Lubricant	Molybdenum disulfide-based			

Note: Contact FITOK Group or our authorized distributors for other materials.

Dimensions

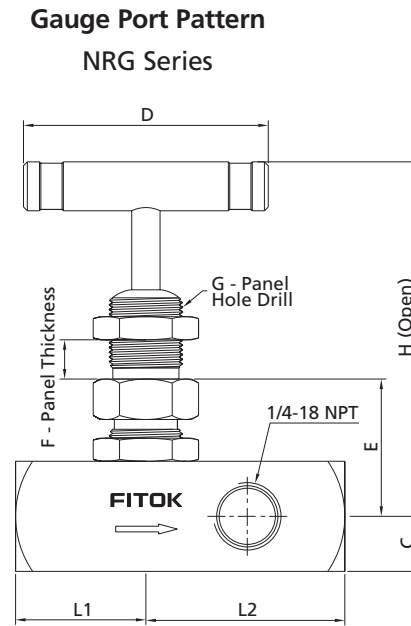
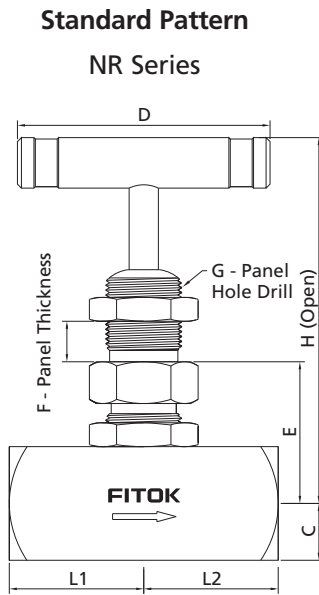

© NR Series Needle Valves are standard without panel mounting. To order needle valves with panel mounting as illustrated, add -Y to the ordering number. Example: NRSS-FNS4-7-Y

Dimensions of NR and NRG Series

Basic Ordering Number	Connection Type and Size		Orifice in.(mm)	Cv	Dimensions, in.(mm)							
	Inlet	Outlet			L1	L2	C	D	E	F	G	H
NR □□-FNS4-7	1/4 Female NPT	1/4 Female NPT	0.19 (4.8)	0.63	1.12 (28.4)	1.12 (28.4)	0.44 (11.1)	2.17 (55.0)	1.28 (32.5)	0.38 (9.7)	0.77 (19.6)	3.77 (95.8)
NR □□-NS4-FNS4-7	1/4 Male NPT	1/4 Female NPT			1.78 (45.2)				1.28 (32.5)			
NR □□-NS8-FNS4-7	1/2 Male NPT	1/4 Female NPT			1.89 (48.0)				1.34 (34.0)			
NRG □□-FNS4-7	1/4 Female NPT	1/4 Female NPT			1.12 (28.4)	1.75 (44.4)						
NRG □□-NS8-FNS4-7	1/2 Male NPT	1/4 Female NPT			3.12 (79.2)							
NR □□-FNS8-8	1/2 Female NPT	1/2 Female NPT	0.25 (6.4)	1.80	1.33 (33.8)	1.33 (33.8)	0.56 (14.3)	2.50 (63.5)	1.40 (35.5)	0.38 (9.7)	0.77 (19.6)	3.83 (97.3)
NR □□-NS8-FNS8-8	1/2 Male NPT	1/2 Female NPT			2.16 (54.9)							
NR □□-NS12-FNS8-8	3/4 Male NPT	1/2 Female NPT			3.33 (84.6)							
NRG □□-FNS8-8	1/2 Female NPT	1/2 Female NPT			3.33 (84.6)	2.25 (57.2)						
NRG □□-NS12-FNS8-8	3/4 Male NPT	1/2 Female NPT										

1. Sizes and types listed are standard. Other sizes and types are available upon request.
2. For dimensions not shown above, please contact FITOK Group or our authorized distributors.

Ordering Number Description

NRSS - NS8 - FNS8 - P8 - BYM - SF2

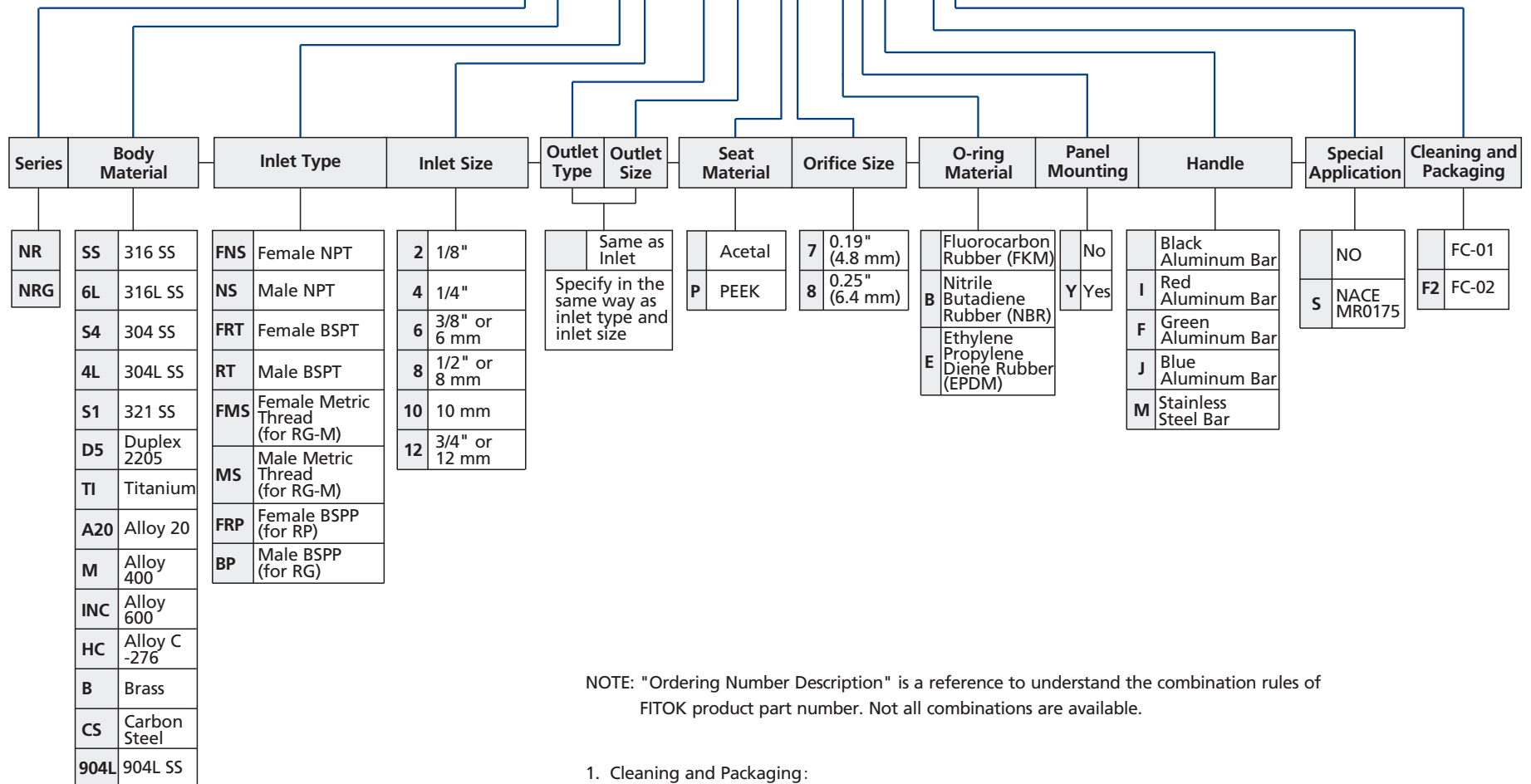

NOTE: "Ordering Number Description" is a reference to understand the combination rules of FITOK product part number. Not all combinations are available.

1. Cleaning and Packaging:

FC-01: Standard cleaning and packaging for general industrial procedures.

FC-02: Special cleaning and packaging for wetted system components to ensure compliance with product cleanliness requirement of ASTM G93 Level C.

Toggle Valves

NT Series

Features

- ⦿ One piece forged body
- ⦿ Straight and angle patterns
- ⦿ Compact design
- ⦿ Quick opening or closing
- ⦿ Nonrotating stem
- ⦿ Panel mounting available
- ⦿ Every valve leak tested with Nitrogen or compressed air at the maximum allowable working pressure
- ⦿ Working pressure up to: 300 psig (20.7 bar)



Technical Data

Orifice in. (mm)	Working Pressure at 100°F (38°C) psig (bar)	O-ring Material	Temperature Rating
0.08 (2.0)	300 (20.7)	Fluorocarbon Rubber (FKM)	-20°F to 400°F (-28°C to 204°C)
0.125 (3.2)		Nitrile Butadiene Rubber (NBR)	-20°F to 212°F (-28°C to 100°C)
0.25 (6.4)	200 (13.8)	Ethylene Propylene Diene Rubber (EPDM)	-20°F to 300°F (-28°C to 148°C)

Standard Materials of Construction

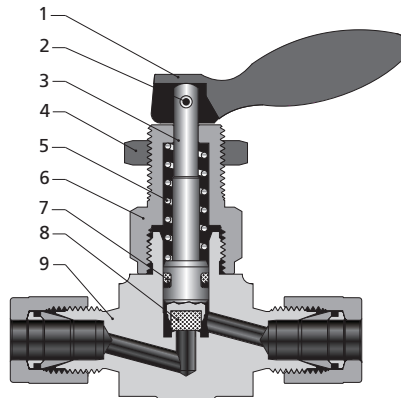

Item	Component	Valve Body Material			
		316 SS	304 SS	321 SS	Brass
		Material Grade/ASTM Specification			
1	Handle	Stainless steel			
2	Pin	Stainless steel			
3	Stem	316 SS/A479	304 SS/A479		316 SS/A479
4	Panel Nut	Stainless steel			Brass C36000/B16
5	Spring	S17700/A313			
6	Bonnet	304 SS/A479			Brass C36000/B16
7	O-ring	Fluorocarbon Rubber (FKM), Nitrile Butadiene Rubber (NBR) or Ethylene Propylene Diene Rubber (EPDM)			
8	Stem Tip	PTFE/D1710			
9	Body	316 SS/A182	304 SS/A182	321 SS/A182	Brass C37700/B283
Lubricant		Molybdenum disulfide-based			

Note: Contact FITOK Group or our authorized distributors for other materials.

Dimensions

Straight Pattern

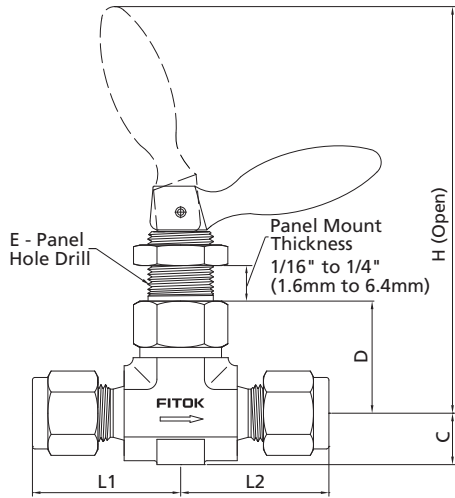

Angle Pattern

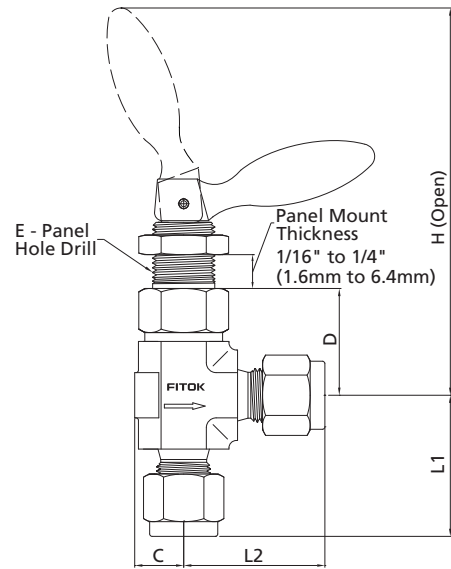

Dimensions of NT series

Basic Ordering Number	Connection Type and Size		Orifice in.(mm)	Cv	Dimensions, in.(mm)					
	Inlet	Outlet			L1	L2	C	D	E	H
NT□□-NS2-5	1/8 Male NPT	1/8 Male NPT	0.08 (2.0)	0.11	0.75 (19.05)	0.75 (19.05)	0.32 (8.2)	0.85 (21.7)	0.53 (13.5)	2.83 (71.9)
NT□□-NS2-FL2-5	1/8 Male NPT	1/8" FITOK			0.75 (19.05)	0.98 (25.0)				
NT□□-FL2-5	1/8" FITOK	1/8" FITOK			0.98 (25.0)	0.98 (25.0)				
NT□□-ML3-5	3 mm FITOK	3 mm FITOK								
NT□□-FNS2-7	1/8 Female NPT	1/8 Female NPT	0.125 (3.2)	0.20	0.81 (20.6)	0.81 (20.6)	0.39 (10.0)	0.85 (21.7)	0.53 (13.5)	2.83 (71.9)
NT□□-NS2-7	1/8 Male NPT	1/8 Male NPT			0.86 (21.8)	0.86 (21.8)				
NT□□-NS4-7	1/4 Male NPT	1/4 Male NPT			0.98 (25.0)	0.98 (25.0)				
NT□□-NS4-FL4-7	1/4 Male NPT	1/4" FITOK			0.98 (25.0)	1.13 (28.7)				
NT□□-FL4-7	1/4" FITOK	1/4" FITOK			1.13 (28.7)					
NT□□-ML6-7	6 mm FITOK	6 mm FITOK								
NT□□-ML8-7	8 mm FITOK	8 mm FITOK								
NT□□-FNS4-8	1/4 Female NPT	1/4 Female NPT			0.25 (6.4)	0.70				
NT□□-FNS6-8	3/8 Female NPT	3/8 Female NPT	1.12 (28.4)	1.12 (28.4)						
NT□□-NS6-8	3/8 Male NPT	3/8 Male NPT	1.29 (32.8)	1.29 (32.8)						
NT□□-FL6-8	3/8" FITOK	3/8" FITOK	1.40 (35.6)	1.40 (35.6)						
NT□□-FL8-8	1/2" FITOK	1/2" FITOK	1.36 (34.5)	1.36 (34.5)						
NT□□-ML10-8	10 mm FITOK	10 mm FITOK	1.46 (37.1)	1.46 (37.1)						
NT□□-ML12-8	12 mm FITOK	12 mm FITOK								

1. Connection type of "FITOK" means FITOK double ferrule tube fittings.
2. Sizes and types listed are standard. Other sizes and types are available upon request. For details, please contact FITOK Group or our authorized distributors.
3. Dimensions are shown with FITOK tube fitting nuts finger-tight. All dimensions are for reference only and are subject to change. For dimensions not shown above, please contact FITOK Group or our authorized distributors.

Pneumatic Actuators

Features

- Valve and actuator are fully assembled and every valve leak tested with Nitrogen or compressed air at the maximum allowable working pressure
- Opens and closes quickly and reliably
- Rotatable actuator port allows easy installation

Actuation Modes

- Normally closed—air opens, spring closes
- Normally open—air closes, spring opens
- Double acting—air opens and closes

Normally Closed and Double Acting

Normally Open



Technical Data

Actuator Type	Working Pressure at 100°F (38°C) psig (bar)	Actuator Pressure Rating psig (bar)
Normally closed	300 (20.7)	87 (6)
Normally open	450 (31.0)	
Double acting		

Component	Material
	Material Grade/ASTM Specification
Housing	Anodized aluminum
Spring	S17700/A313
Mounting Bracket	304SS/A240
Stem Tip	Normally open, normally closed—PTFE/D1710, double acting—PCTFE/D1430

Please refer to NT Series "Standard Materials of Construction" for other materials.

Dimensions

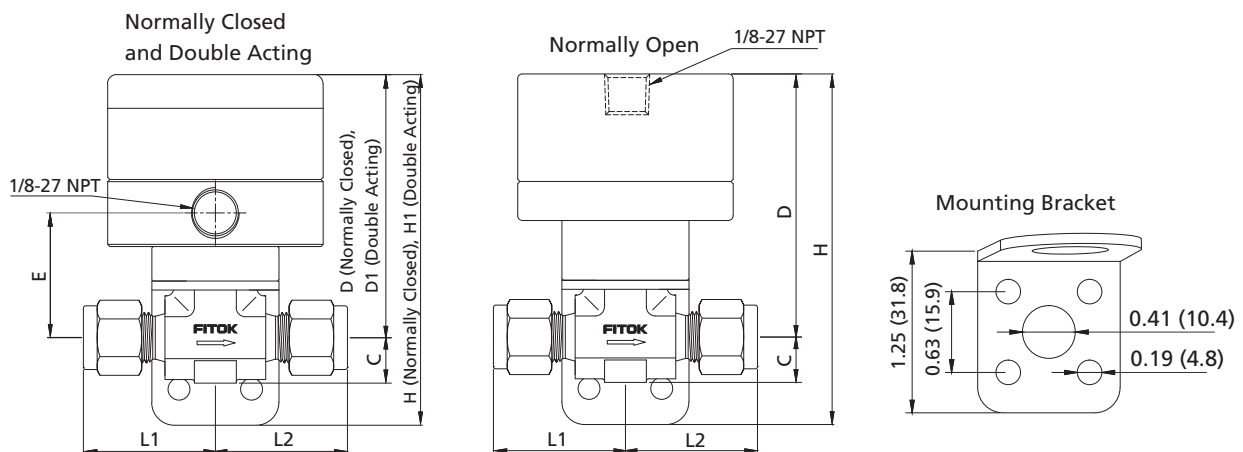

Basic Ordering Number	Connection Type and Size		Orifice in.(mm)	Cv	Dimensions, in.(mm)							
	Inlet	Outlet			L1	L2	C	D	D1	H	H1	E
NT□□-NS2-5-C-Y	1/8 Male NPT	1/8 Male NPT	0.08 (2.0)	0.11	0.86 (21.8)	0.86 (21.8)						
NT□□-NS2-FL2-5-C-Y	1/8 Male NPT	1/8" FITOK			0.86 (21.8)	1.03 (26.2)						
NT□□-FL2-5-C-Y	1/8" FITOK	1/8" FITOK			1.03 (26.2)	1.03 (26.2)						
NT□□-ML3-5-C-Y	3 mm FITOK	3 mm FITOK										
NT□□-FNS2-7-C-Y	1/8 Female NPT	1/8 Female NPT	0.125 (3.2)	0.20	0.81 (20.6)	0.81 (20.6)	0.39 (10.0)	2.28 (58)	2.46 (62.5)	3.04 (77.3)	3.22 (81.8)	1.08 (27.5)
NT□□-NS2-7-C-Y	1/8 Male NPT	1/8 Male NPT			0.86 (21.8)	0.86 (21.8)						
NT□□-NS4-7-C-Y	1/4 Male NPT	1/4 Male NPT			0.98 (25.0)	0.98 (25.0)						
NT□□-NS4-FL4-7-C-Y	1/4 Male NPT	1/4" FITOK			0.98 (25.0)							
NT□□-FL4-7-C-Y	1/4" FITOK	1/4" FITOK				1.13 (28.7)						
NT□□-ML6-7-C-Y	6 mm FITOK	6 mm FITOK										
NT□□-ML8-7-C-Y	8 mm FITOK	8 mm FITOK										

1. Connection type of "FITOK" means FITOK double ferrule tube fittings.
2. Sizes and types listed are standard. Other sizes and types are available upon request. For details, please contact FITOK Group or our authorized distributors.
3. Dimensions are shown with FITOK tube fitting nuts finger-tight. All dimensions are for reference only and are subject to change. For dimensions not shown above, please contact FITOK Group or our authorized distributors.

Ordering Number Description

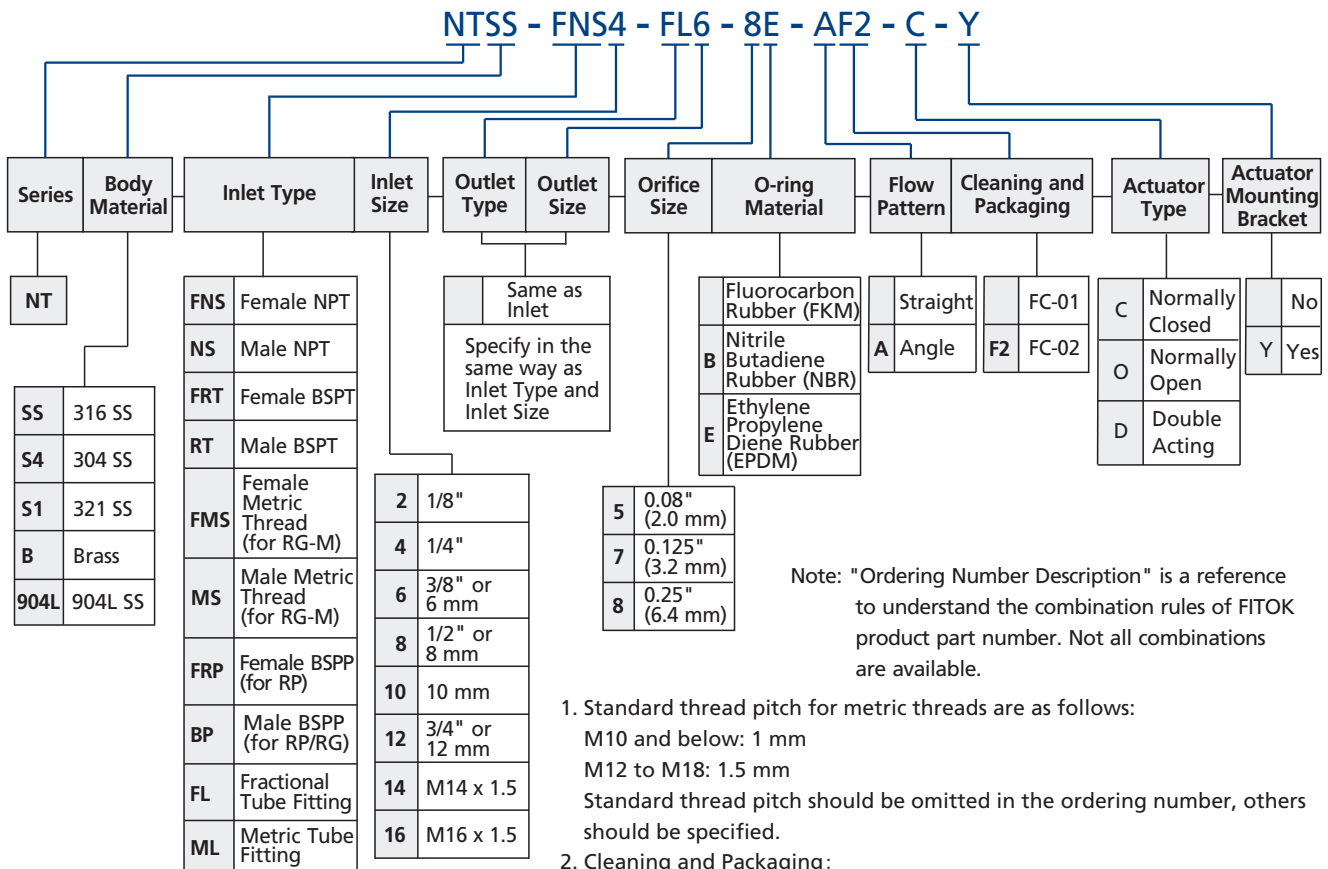

1. Standard thread pitch for metric threads are as follows:
 M10 and below: 1 mm
 M12 to M18: 1.5 mm
 Standard thread pitch should be omitted in the ordering number, others should be specified.
2. Cleaning and Packaging:
 FC-01: Standard cleaning and packaging for general industrial procedures.
 FC-02: Special cleaning and packaging for wetted system components to ensure compliance with product cleanliness requirement of ASTM G93 Level C.

Union Bonnet Needle Valves

NU Series: Working pressure up to 6000 psig

NUH Series: Working pressure up to 10000 psig

Features

- ⦿ One-piece forged body
- ⦿ Two-piece stem design: Upper stem threads cold rolled and lower stem hardened for high strength and smooth operation
- ⦿ Accidental valve disassembly disabled by union bonnet construction
- ⦿ Upper stem thread lubricant isolated from system media
- ⦿ Linear instead of rotary movement of the rising, non-rotating stem minimizes packing abrasion and reduces the friction between the seat and the tip
- ⦿ Safety back seating seal in fully open position
- ⦿ Panel mounting available
- ⦿ Steady and durable fastening of the handle by double lock-pins
- ⦿ Handles of different colors available
- ⦿ Every valve leak tested with Nitrogen or compressed air (NU Series) at the maximum allowable working pressure or with water (NUH Series) at 1.1 times the maximum allowable pressure
- ⦿ Working pressure up to:
 - NU Series—Stainless steel: 6000 psig (414 bar)
 - Alloy C-276: 6000 psig (414 bar)
 - Alloy 400: 5000 psig (345 bar)
 - Titanium: 3500 psig (241 bar)
 - NUH Series—Stainless steel: 10000 psig (690 bar)
- ⦿ Working temperature:
 - PTFE: -65°F to 450°F (-54°C to 232°C)
 - PEEK: -65°F to 500°F (-54°C to 260°C)
 - Graphite: -65°F to 1200°F (-54°C to 649°C)



Pressure vs. Temperature

NU Series

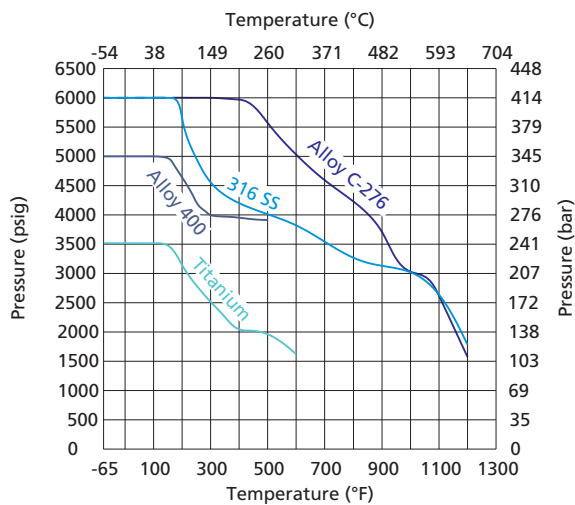

NUH Series

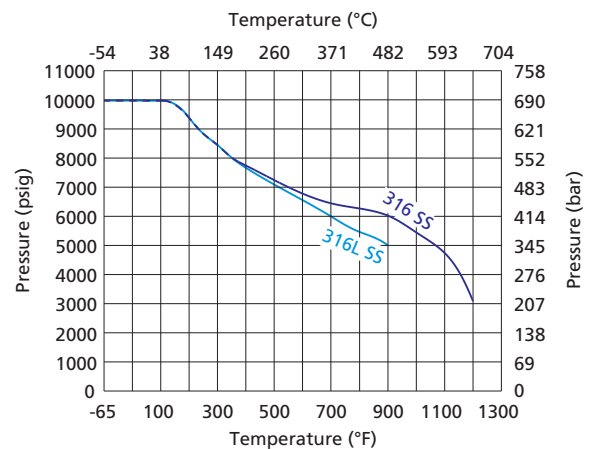

1. Graphs are based on graphite packing.
2. Soft tips are for NU Series only. Temperature rating is limited to 200°F (93°C) max. with PCTFE stem tip (soft tip).
3. Contact FITOK Group or our authorized distributors for curve graph of other materials.

Flow Data at 100°F (37°C)

Regulating Stem

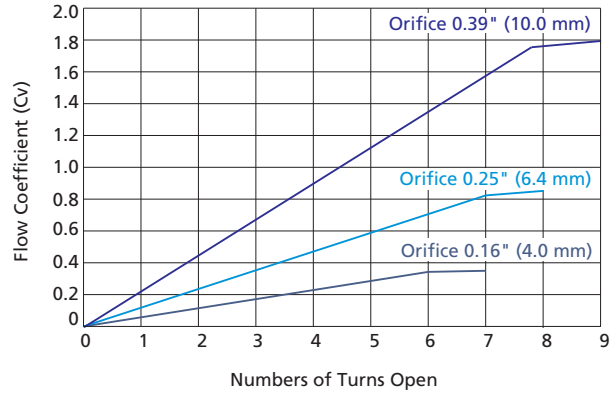

Standard Materials of Construction

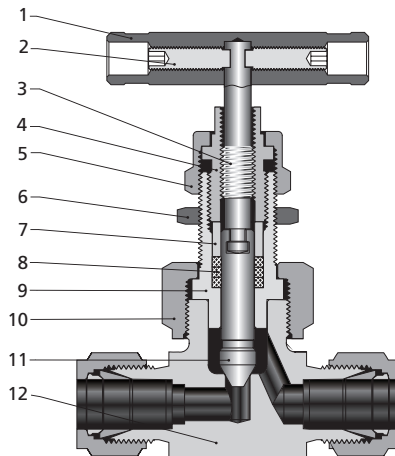

Stem Type

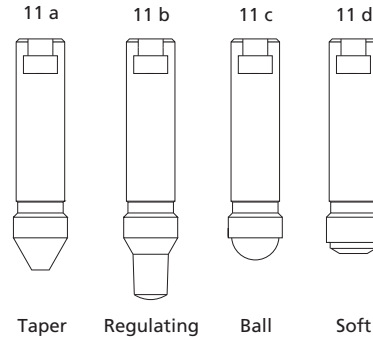

Needle Valves
Metering Valves

Item	Component	Valve Body Material			
		316 SS	Alloy 400	Titanium	Alloy C-276
		Material Grade/ASTM Specification			
1	Handle	Anodized aluminium or stainless steel or black knob			
2	Set Screw	Galvanized carbon steel			
3	Upper Stem	316 SS/A479			
4	Packing Bolt	304 SS/A479			
5	Lock Nut	316 SS/A479			
6	Panel Nut	Stainless steel			
7	Gland	316 SS/A479			
8	Packing	PTFE or PEEK or graphite			
9	Bonnet	316 SS/A479	Alloy 400/B164	Titanium Gr 4/B348	Alloy C-276/B574
10	Union Nut	316 SS/A479			
11a 11b 11c	Lower Stem	Hardened 316 SS/A479	Alloy 400/B164	Titanium Gr 4/B348	Alloy C-276/B574
11d	Stem	316 SS/A479	Alloy 400/B164	Titanium Gr 4/B348	Alloy C-276/B574
	Stem Tip	PTFE or PCTFE or PEEK			
11e	Stem	316 SS/A479	Not Applicable		Alloy C-276/B574
	Stem Tip	Stellite			
12	Body	316 SS/A182	Alloy 400/B164, B127, B564	Titanium Gr 4/B348 or titanium Gr 4/B381	Alloy C-276/B564
	Seat	Same as Body			
Lubricant		Molybdenum disulfide-based			

Note: Contact FITOK Group or our authorized distributors for other materials.

Dimensions

Straight Pattern

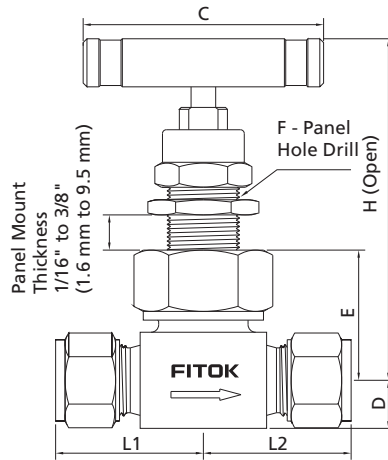

Angle Pattern

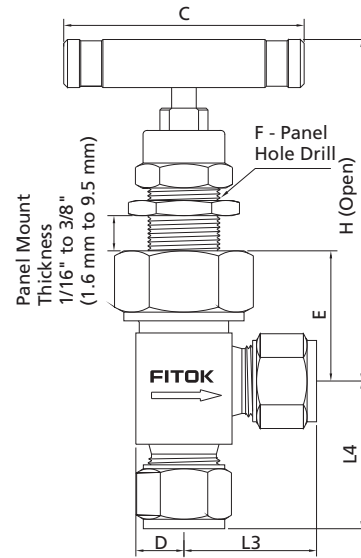

Dimensions of NU Series

Basic Ordering Number	Connection Type and Size	Connection Pressure at 100°F (38°C) psig (bar)	Orifice in.(mm)	Cv	Dimensions, in.(mm)														
					Inlet/Outlet	316 SS	L1	L2	L3	L4	C	D	E	F	H				
NU□□-FNS2-7	1/8 Female NPT	6000 (414)	0.16 (4.0)	0.35	1.00 (25.4)	1.00 (25.4)	0.89 (22.6)	1.00 (25.4)	1.75 (44.5)	0.39 (9.9)	1.09 (27.7)	0.59 (15.0)	3.06 (77.7)						
NU□□-FNS4-7	1/4 Female NPT				1.03 (26.2)	1.03 (26.2)													
NU□□-NS4-FNS4-7	1/4 Male NPT/ 1/4 Female NPT				1.00 (25.4)	1.03 (26.2)													
NU□□-NS4-7	1/4 Male NPT				1.00 (25.4)	1.00 (25.4)	1.00 (25.4)												
NU□□-NS6-7	3/8 Male NPT				1.03 (26.2)	1.03 (26.2)	0.89 (22.6)												
NU□□-FRP4-7	1/4 Female BSPP				1.00 (25.4)	1.22 (30.9)	1.14 (29.0)												
NU□□-NS4-FL4-7	1/4 Male NPT/ 1/4" FITOK				1.03 (26.2)	1.22 (30.9)													
NU□□-FNS4-FL4-7	1/4 Female NPT/ 1/4" FITOK				1.22 (30.9)	1.22 (30.9)	1.15 (29.2)							1.22 (30.9)					
NU□□-FL4-7	1/4" FITOK				1.00 (25.4)	1.00 (25.4)	0.85 (21.6)							1.00 (25.4)					
NU□□-ML6-7	6 mm FITOK				1.03 (26.2)	1.03 (26.2)	1.10 (28.0)							1.10 (28.0)					
NU□□-ML8-7	8 mm FITOK				1.03 (26.2)	1.03 (26.2)	1.10 (28.0)							1.10 (28.0)					
NU□□-TS4-7-G	1/4" Tube Socket Weld				1.13 (28.6)	1.13 (28.6)	1.00 (25.4)							1.13 (28.6)					
NU□□-FO4-7	1/4" Male FO				1.06 (26.9)	2.50 (63.5)	0.50 (12.7)							1.34 (34.0)	0.78 (19.8)	3.78 (96.0)			
NU□□-FR4-7	1/4" Male FR				1.41 (35.9)												1.41 (35.9)	1.28 (32.5)	1.47 (37.3)
NU□□-FNS4-8	1/4 Female NPT				1.52 (38.6)												1.52 (38.6)	1.40 (35.6)	1.58 (40.1)
NU□□-FNS6-8	3/8 Female NPT				1.42 (36.1)												1.42 (36.1)	1.30 (33.0)	1.48 (37.6)
NU□□-NS6-8	3/8 Male NPT	1.42 (36.1)	1.42 (36.1)	1.30 (33.0)	1.48 (37.6)														
NU□□-FL6-8	3/8" FITOK																		
NU□□-FL8-8	1/2" FITOK																		
NU□□-ML10-8	10 mm FITOK																		

Dimensions of NU Series

Basic Ordering Number	Connection Type and Size Inlet/Outlet	Connection Pressure at 100°F (38°C) psig (bar) 316 SS	Orifice in.(mm)	Cv	Dimensions, in.(mm)								
					L1	L2	L3	L4	C	D	E	F	H
NU□□-ML12-8	12 mm FITOK	6000 (414)	0.25 (6.4)	0.86	1.52 (38.6)	1.52 (38.6)	1.40 (35.6)	1.58 (40.1)	2.50 (63.5)	0.50 (12.7)	1.34 (34.0)	0.78 (19.8)	3.78 (96.0)
NU□□-ML14-8	14 mm FITOK												
NU□□-ML16-8	16 mm FITOK												
NU□□-TS6-8-G	3/8" Tube Socket Weld	6000 (414)											
NU□□-TS8-8-G	1/2" Tube Socket Weld												
NU□□-PS4-8-G	1/4 Pipe Socket Weld												
NU□□-MTS12-8-G	12 mm Tube Socket Weld												
NU□□-MTS14-8-G	14 mm Tube Socket Weld												
NU□□-MTS16-8-G	16 mm Tube Socket Weld												
NU□□-MTB14-8-G	14x2.5 mm Tube Butt Weld												
NU□□-MTB16-8-G	16x2.8 mm Tube Butt Weld												
NU□□-UMB14-8	14x2.5 mm Rotatable Tube Butt Weld												
NU□□-FO8-8	1/2" Male FO												
NU□□-FR8-8	1/2" Male FR												
NU□□-MS20-8	M20 x 1.5 Male Metric												
NU□□-MS22-8	M22 x 1.5 Male Metric												
NU□□-NS8-9	1/2 Male NPT	6000 (414)	0.39 (10.0)	1.8	1.56 (39.6)	1.56 (39.6)	1.56 (39.6)	1.56 (39.6)	3.50 (88.9)	0.63 (16.0)	1.82 (46.2)	1.03 (26.2)	4.76 (121)
NU□□-FNS8-9	1/2 Female NPT												
NU□□-FNS12-9	3/4 Female NPT												
NU□□-NS12-9	3/4 Male NPT												
NU□□-FL8-9	1/2" FITOK												
NU□□-FL12-9	3/4" FITOK												
NU□□-ML14-9	14 mm FITOK												
NU□□-ML16-9	16 mm FITOK												
NU□□-ML18-9	18 mm FITOK												
NU□□-ML20-9	20 mm FITOK												
NU□□-MTS14-9-G	14 mm Tube Socket Weld												
NU□□-MTS16-9-G	16 mm Tube Socket Weld												
NU□□-TS8-9-G	1/2" Tube Socket Weld												
NU□□-TS12-9-G	3/4" Tube Socket Weld												
NU□□-MTB16-9-G	16x2.25 mm Tube Butt Weld												
NU□□-UMB14-9	14x2.5 mm Rotatable Tube Butt Weld												
NU□□-FR8-9	1/2" Male FR												
NU□□-MS27-9	M27 x 2 Male Metric												

Needle Valves
Metering Valves

1. Connection type of "FITOK" means FITOK double ferrule tube fittings. When the connection type of valves is FITOK double ferrule tube fitting, the working pressures of the valves are related to the wall thickness of tubing applied. For specific working pressure of the valves, please refer to the allowable working pressures in FITOK Catalog Tubing.
2. Connection type of FO means O-ring face seal fittings. "FR" means metal gasket face seal fittings.
3. Sizes and types listed are standard. Other sizes and types are available upon request. For details, please contact FITOK Group or our authorized distributors.
4. Dimensions are shown with FITOK tube fitting nuts finger-tight. All dimensions are for reference only and are subject to change. For dimensions not shown above, please contact FITOK Group or our authorized distributors.

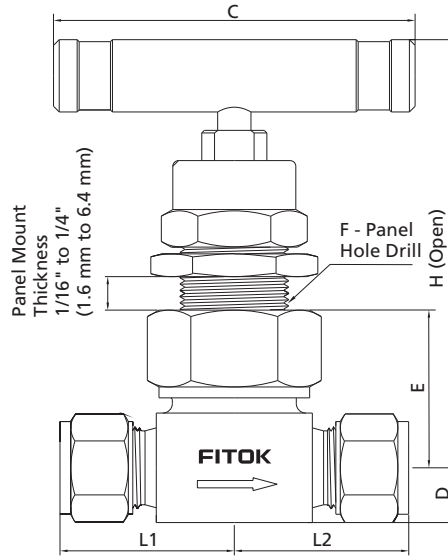

Dimensions of NUH Series

Basic Ordering Number	Connection Type and Size	Connection Pressure at 100°F (38°C) psig (bar)	Orifice in.(mm)	Cv	Dimensions, in.(mm)						
					Inlet/Outlet	316 SS	L1	L2	C	D	E
NUH□□-FL4-7	1/4" FITOK	10000 (690)	0.16 (4.0)	0.35	1.41 (35.8)	1.41 (35.8)	2.50 (63.5)	0.50 (12.7)	1.35 (34.3)	0.78 (19.8)	3.74 (95.0)
NUH□□-FNS2-7	1/8 Female NPT										
NUH□□-FNS4-7	1/4 Female NPT										
NUH□□-NS4-FNS4-7	1/4 Male NPT/ 1/4 Female NPT										
NUH□□-NS4-7	1/4 Male NPT										
NUH□□-TS4-7-G	1/4" Tube Socket Weld										
NUH□□-FNS4-8	1/4 Female NPT		0.25 (6.4)	0.86	1.56 (39.7)	1.56 (39.7)	3.50 (88.9)	0.63 (16.0)	1.77 (45.0)	1.03 (26.2)	4.90 (124.5)
NUH□□-NS8-8	1/2 Male NPT										
NUH□□-TS8-8-G	1/2" Tube Socket Weld										
NUH□□-MTS12-8-G	12 mm Tube Socket Weld										
NUH□□-MTS16-9-G	16 mm Tube Socket Weld										
NUH□□-MTB22-9-G	22x5 mm Tube Butt Weld										
NUH□□-FNS8-9	1/2 Female NPT	0.39 (10.0)	1.8	1.75 (44.5)	1.75 (44.5)	3.50 (88.9)	0.91 (23.0)	2.29 (58.2)	1.14 (28.9)	5.28 (134.1)	
				1.56 (39.7)	1.56 (39.7)						

1. Connection type of "FITOK" means FITOK double ferrule tube fittings. When the connection type of valves is FITOK double ferrule tube fitting, the working pressures of the valves are related to the wall thickness of tubing applied. For specific working pressure of the valves, please refer to the allowable working pressures in FITOK Tubing catalog.
2. Sizes and types listed are standard. Other sizes and types are available upon request. For details, please contact FITOK Group or our authorized distributors.
3. Dimensions are shown with FITOK tube fitting nuts finger-tight. All dimensions are for reference only and are subject to change. For dimensions not shown above, please contact FITOK Group or our authorized distributors.

Ordering Number Description

NUSS - FNS6 - FL6 - 8WB - GM - ASF2

Series	Body Material		Inlet Type		Inlet Size	Outlet Type	Outlet Size	Orifice Size		Stem Tip Material		Stem Tip Type	Packing Material	Handle	Flow Pattern	Special Application	Cleaning and Packaging		
NU	SS	316 SS	FNS	Female NPT	2	1/8"	Same as Inlet	7	0.16" (4.0 mm)	Same as Body	Taper	PTFE		Straight		FC-01			
NUH	6L	316L SS	NS	Male NPT	4	1/4"	Specify in the same way as inlet type and inlet size	8	0.25" (6.4 mm)	W	Stellite	R	Regulating	P	PEEK	A	Angle	F2	FC-02
	S4	304 SS	FRT	Female BSPT	6	3/8" or 6 mm			9	0.39" (10 mm)	D5	Duplex 2205	B	Ball	G	Graphite			
	4L	304L SS	RT	Male BSPT	8	1/2" or 8 mm				TI	Titanium	T	Soft Tip-PTFE (only for NU Series Needle Valves)						
	S1	321 SS	FMS	Female Metric Thread (for RG-M)	10	10 mm				A20	Alloy 20	K	Soft Tip-PCTFE (only for NU Series Needle Valves)						
	91	F91	MS	Male Metric Thread (for RG-M)	12	3/4" or 12 mm				M	Alloy 400	P	Soft Tip-PEEK (only for NU Series Needle Valves)						
	92	F92	FRP	Female BSPP (for RP)	14	14 mm or 14x2.5 mm or M14x1.5				INC	Alloy 600								
	D5	Duplex 2205	BP	Male BSPP (for RP and RG)	16	1" or 16 mm or 16x2.25 mm or 16x2.8 mm				HC	Alloy C-276								
	TI	Titanium	TS	Fractional Tube Socket Weld	18	18 mm													
	A20	Alloy 20	MTS	Metric Tube Socket Weld	20	20 mm or M20 x 1.5													
	M	Alloy 400	TB	Fractional Tube Butt Weld	22	22 mm or 22x5 mm or M22x1.5													
	INC	Alloy 600	MTB	Metric Tube Butt Weld	24	M24 x 1.5													
	HC	Alloy C-276	PS	Pipe Socket Weld	25	25 mm													
	B	Brass	PB	Pipe Butt Weld	27	M27 x 2													
	CS	Carbon Steel	FL	Fractional Tube Fitting															
	904L	904L SS	ML	Metric Tube Fitting															
			UFB	Rotatable Fractional Tube Butt Weld															
			UMB	Rotatable Metric Tube Butt Weld															
			FO	Male FO Fitting															
			FR	Male FR Fitting															

NOTE: "Ordering Number Description" is a reference to understand the combination rules of FITOK product part number. Not all combinations are available.

- Standard thread pitch for metric threads are as follows:
M10 and below: 1 mm
M12 to M24: 1.5 mm
M27 and above: 2 mm
Standard thread pitch should be omitted in the ordering number, others should be specified.
- FO means FITOK O-ring face seal fittings.
- FR means FITOK metal gasket face seal fittings.
- Cleaning and Packaging:
FC-01: Standard cleaning and packaging for general industrial procedures.
FC-02: Special cleaning and packaging for wetted system components to ensure compliance with product cleanliness requirement of ASTM G93 Level C.
- Special Application:
Plural special application designators available in one ordering number, example: NUSS-NS4-7-SSI.
SilcoNert® 2000 (Sulfinert®) coating: Wetted metal components SilcoNert® 2000 (Sulfinert®) coated.

Outside Screw and Yoke (OS&Y) Needle Valves

NY Series: Working pressure up to 6000 psig

Features

- ⦿ Cold drawn bar as body
- ⦿ Standard seat diameter 0.16" (4mm). Cv: 0.35 standard
- ⦿ Hardened stem threads prevent galling
- ⦿ Stem threads completely isolated from system media
- ⦿ Linear instead of rotary motion of the rising, non-rotating stem minimizes packing abrasion and reduces the friction between the seat and the tip
- ⦿ Externally adjustable gland, independent of spindle thread
- ⦿ Steady and durable fastening of the handle by double lock-pins
- ⦿ Bottom mounting available
- ⦿ Every valve leak tested with Nitrogen or compressed air at maximum allowable working pressure
- ⦿ Working pressure up to:
 - Stainless steel: 6000 psig (414 bar)
 - Alloy C-276: 6000 psig (414 bar)
 - Alloy 400: 5000 psig (345 bar)
- ⦿ Working temperature:
 - PTFE: -65°F to 450°F (-54°C to 232°C)
 - PEEK: -65°F to 500°F (-54°C to 260°C)
 - Graphite: -65°F to 1200°F (-54°C to 649°C)



Pressure vs. Temperature

NY Series

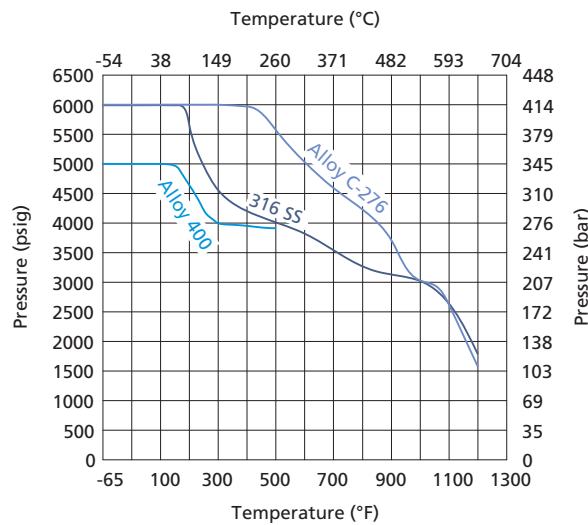

1. Graphs are based on graphite packing.
2. Contact FITOK Group or our authorized distributors for curve graph of other materials.

Standard Materials of Construction

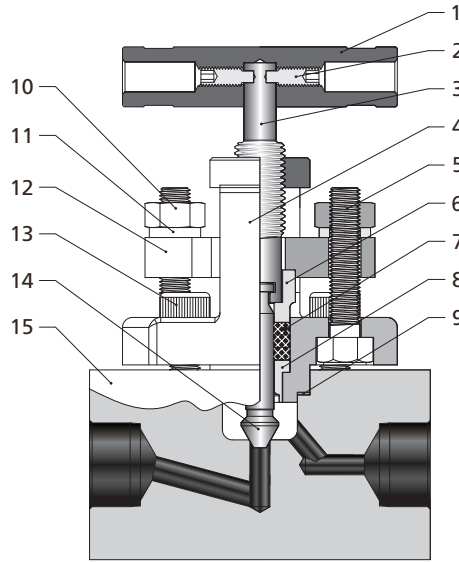

Item	Component	Valve Body Material
		316 SS
		Material Grade/ASTM Specification
1	Handle	Anodized aluminum or stainless steel
2	Set Screw	Galvanized carbon steel
3	Upper Stem	316 SS/A479
4	Yoke	316 SS/A182
5	Bolts	Stainless steel
6	Packing Washer	316 SS/A479
7	Packing	PTFE or PEEK or graphite
8	Packing Washer	316 SS/A479
9	Joint Seal	316 SS/A479
10	Nuts	Stainless steel
11	Gaskets	Stainless steel
12	Gland bridge	316 SS/A182
13	Bolts	Stainless steel
14	Lower Stem	Hardened 316 SS/A479
15	Body	316 SS/A479
	Lubricant	Molybdenum disulfide-based

Note: Contact FITOK Group or our authorized distributors for other materials.

Dimensions of NY Series

Basic Ordering Number	Connection Type and Size		Orifice in.(mm)	Cv	Dimensions, in.(mm)		
	Inlet	Outlet			A	B	C
NY□□-FNS4	1/4 Female NPT	1/4 Female NPT	0.16 (4.0)	0.35	2.69 (68.2)	1.50 (38.1)	4.04 (102.7)
NY□□-NS4	1/4 Male NPT	1/4 Male NPT			2.95 (75.0)		
NY□□-NS4-FNS4	1/4 Male NPT	1/4 Female NPT			2.72 (69.2)		
NY□□-FNS6	3/8 Female NPT	3/8 Female NPT			2.93 (75.0)		
NY□□-NS6	3/8 Male NPT	3/8 Male NPT			3.00 (76.2)		
NY□□-FNS8	1/2 Female NPT	1/2 Female NPT			3.27 (82.0)		
NY□□-NS8	1/2 Male NPT	1/2 Male NPT			3.00 (76.2)		
NY□□-NS8-FNS8	1/2 Male NPT	1/2 Female NPT			3.00 (76.2)		
NY□□-PS8-G	1/2 Pipe Socket Weld	1/2 Pipe Socket Weld			3.54 (89.8)		
NY□□-PB8-G	1/2×SCH80 Pipe Butt Weld	1/2×SCH80 Pipe Butt Weld			3.44 (87.4)		
NY□□-FL4	1/4" FITOK	1/4" FITOK			3.50 (88.9)		
NY□□-FL6	3/8" FITOK	3/8" FITOK			3.78 (96.0)		
NY□□-FL8	1/2" FITOK	1/2" FITOK			3.44 (87.4)		
NY□□-ML6	6 mm FITOK	6 mm FITOK			3.78 (96.0)		
NY□□-ML8	8 mm FITOK	8 mm FITOK			3.78 (96.0)		
NY□□-ML12	12 mm FITOK	12 mm FITOK					

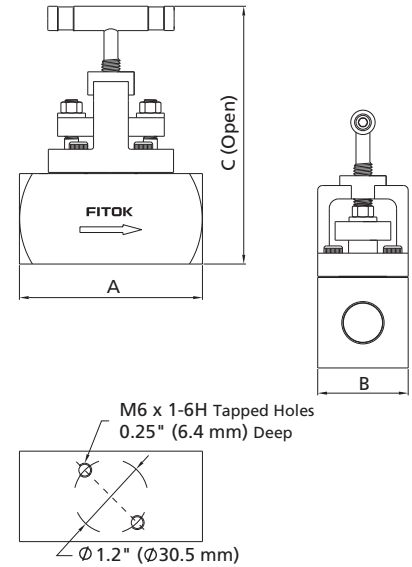

1. Connection type of "FITOK" means FITOK double ferrule tube fittings. When the connection type of valves is FITOK double ferrule tube fitting, the working pressures of the valves are related to the wall thickness of tubing applied. For specific working pressure of the valves, please refer to the allowable working pressures in FITOK Catalog Tubing.
2. Sizes and types listed are standard. Other sizes and types are available upon request. For details, please contact FITOK Group or our authorized distributors.
3. Dimensions are shown with FITOK tube fitting nuts finger-tight. All dimensions not shown above, please contact FITOK Group or our authorized distributors.

Ordering Number Description

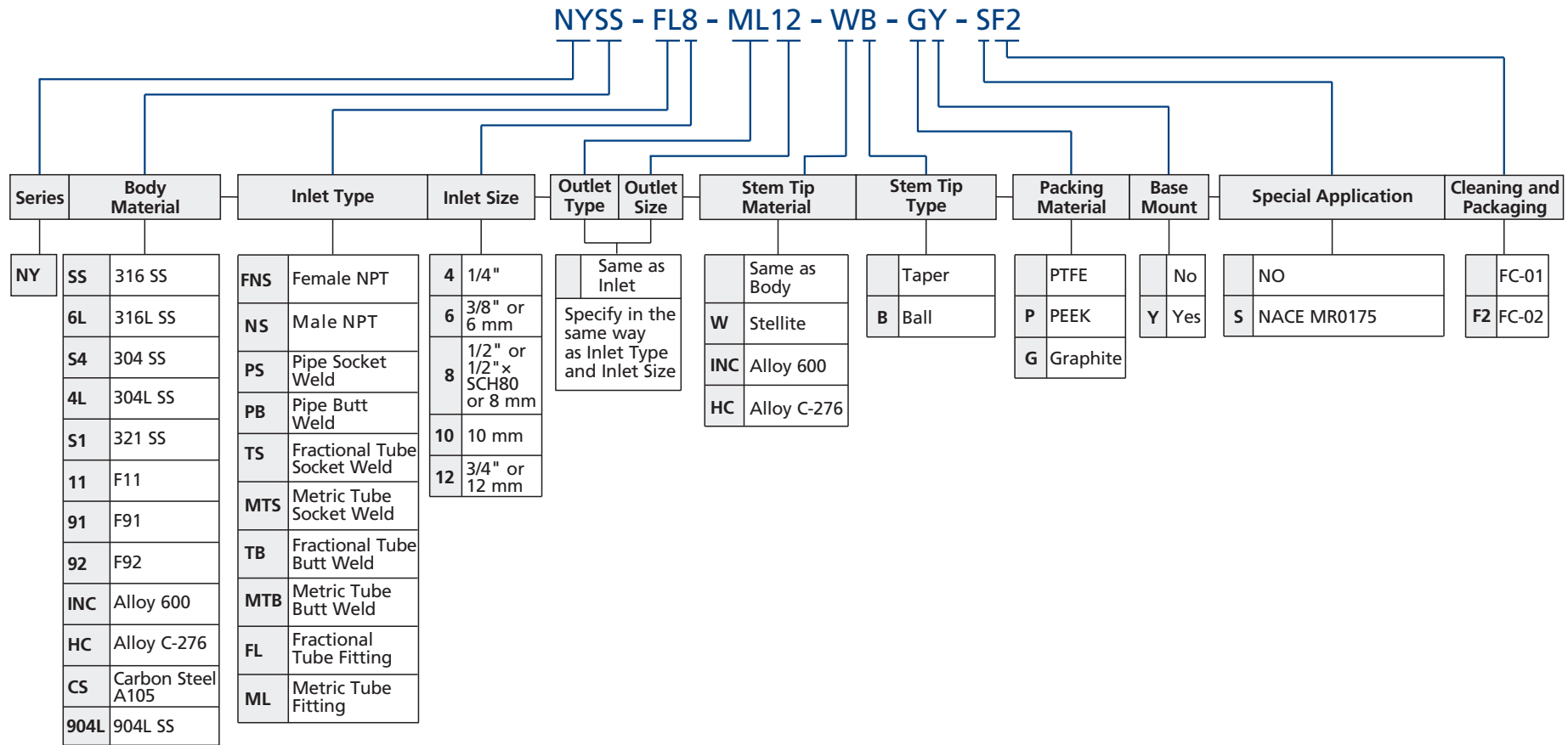

NOTE: "Ordering Number Description" is a reference to understand the combination rules of FITOK product part number. Not all combinations are available.

Cleaning and Packaging:

FC-01: Standard cleaning and packaging for general industrial procedures.

FC-02: Special cleaning and packaging for wetted system components to ensure compliance with product cleanliness requirement of ASTM G93 Level C.

info@fitok.com
www.fitok.com

FK-IC-GV-02-EN- 230829